



FyreGuard®

**ZERO-CLEARANCE
GREASE DUCT**

DELIVERING THE CERTAINTY
OF ZERO-LEAK PERFORMANCE



FyreGuard®

ZERO-CLEARANCE GREASE DUCT

THE FyreGuard® GREASE DUCT, WITH ZERO CLEARANCE TO COMBUSTIBLES, ELIMINATES THE NEED FOR A FIRE-RATED CHASE.

FyreGuard® brings a new level of fire safety protection to food service applications. From restaurants to sports arenas, and other locations that require the venting of cooking/grilling fumes and particulates, FyreGuard® systems provide trouble-free installation, fast project completion and upgraded security.

LISTING

The Schebler FyreGuard® grease duct system has an Underwriters Laboratories Inc. (UL) 2221 Classification under file number R25748 and control number 41RE as a **zero clearance** to combustibles, 2-hour fire-rated grease duct. It also has the Underwriters Laboratories mark for Canada (cUL).

SYSTEM CONCEPT

- Prefabricated, modular, double-wall system
- 4-inch insulation (11 lbs. per sq. in.) with **zero clearance** to combustibles
- Easy-to-handle section lengths connected with the RapidLock® Connection System

SURROUNDINGS

- Suitable for Type 1 or 2 grease hoods, installed per instructions
- May be enclosed with combustible construction
- Enclosed system may be adjacent to walls of combustible construction at **zero clearance**, per UL 2221 Classification

COMPLETE LINE OF FITTINGS AND SIZES AVAILABLE

- Even/odd diameters from 5" to 38" standard
- Standard components: straight sections, variable length joints, tees, elbows, cleanouts, rain caps, roof penetration components and support members
- Special order components: virtually any custom fittings

MATERIAL AVAILABLE

The FyreGuard® system is available in a variety of materials, allowing the proper material selection for your specific application. The standard product features a 304 stainless steel liner and 430 stainless steel outer shell. For greater corrosion resistance, 316 stainless steel is available for the liner and 304 or 316 stainless steel for the outer shell.

MATERIAL THICKNESS

The standard 304 stainless steel inner shell thickness is 0.036". The Standard 430 stainless steel outer shell thickness is 0.028".

SUPPORT LIMITS

Support plates and wall supports are utilized to support the weight of the chimney and to provide a fixed point, allowing the proper operation of expansion joints. In horizontal runs, supports should be placed adjacent to fittings not otherwise supported. See the individual part description for allowable support charts.

TESTS PERFORMED

The FyreGuard® system has endured rigorous tests to obtain the listing. The tests performed include:

STRUCTURAL TESTS

The support plates and wall supports have been physically tested to carry a load four times the amount allowed by our listing.

WIND LOAD TESTS

Loads equivalent to a 110-mph wind have been applied to the chimney with acceptable results.

ZERO CLEARANCE TO COMBUSTIBLES

The system has been subjected to a series of burn tests at temperatures up to 2,000°F. The purpose of these tests is to determine **zero clearances** from the system's outer shell to combustible materials.

FIRE BARRIER

The system and fire stop have been subjected to temperatures up to 2,000°F to ensure the structural integrity of the system and effectiveness of the fire stop in preventing fire passage to multiple floors of a building's structure.

SCHEBLER VALUE

FAST PROJECT COMPLETION

- Short lead times
- Trouble-free installation/detailed instructions
- No on-site welding

MAXIMUM STRENGTH / LONG LIFE

- Unmatched dimensional accuracy for secure joint connections
- Fully welded liners and shells
- Unequaled support limits

COMPLETE SYSTEM DESIGN

- CAD drawings
- 3D design solutions
- Complete BOM
- System sizing

SPECIAL FITTINGS

- Customized components are available to meet the needs of your specific project



PART NUMBERS

All standard parts manufactured by Schebler are identified by a part number that describes their makeup and function.

The part numbers are made up as follows:

1. The first series is the model designation, FG.
2. This is followed by the part name. For example, 47S, 90T or VS.
3. Next is the part's internal diameter in inches, such as 06, 12 or 24.
4. Last is the liner/shell material designation.

CODE	LINER / SHELL MATERIAL
A	304 / Aluminized
B	316 / Aluminized
C	304 / 304 or all 304
D	304 / 316
E	316 / 316 or all 316
F	Galvanized
G	Aluminized
H	Painted Carbon Steel
N	304 / 430
P	316 / 430
Q	430
S	316 / 304

For example, the part number for an 8" ID, Model FG, 47" long straight section with a 304 stainless steel liner and 430 stainless steel shell is: FG-47S-08N.

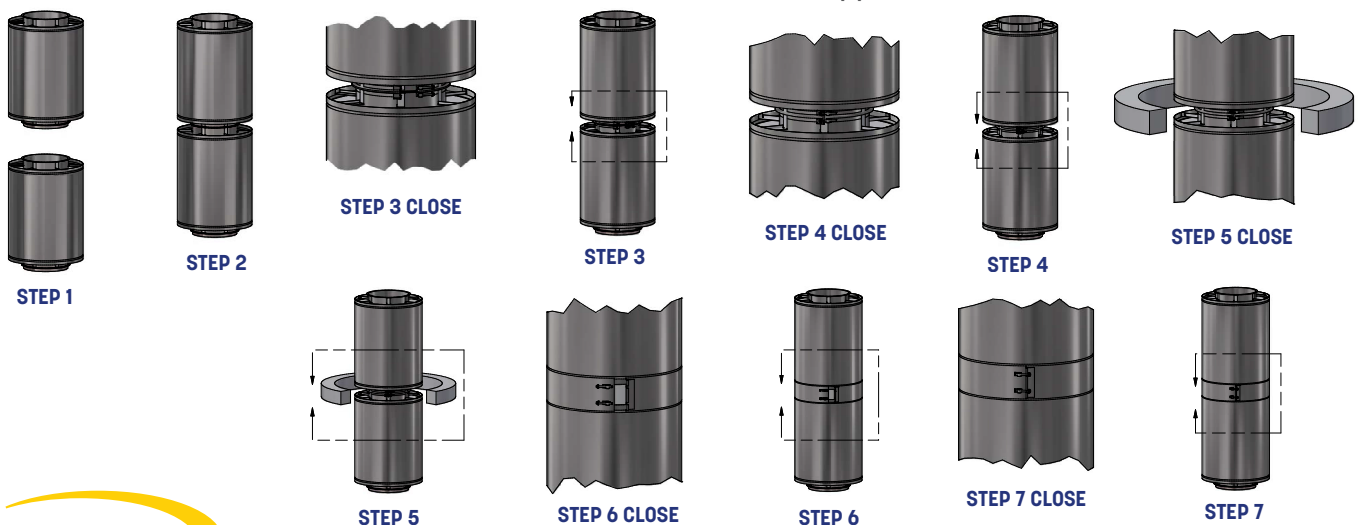

JOINT ASSEMBLY

Note: Wipe the inner bands and flanges clean prior to assembly.

Steps:

1. Insert the component with the gasket and internal collar into the previously installed component.
2. Align the flanges so they are flush to one another.
3. Affix the inner band to the flange, pulling the band tight to allow the bolts to slot into the clip of the band.
4. Once slotted, tighten the bolts using a 3/8" nut driver to tighten the inner band around the flanges of the pipe. Use a rubber or rawhide mallet to assist in drawing the band together as the bolts are tightened.
5. Install the insulation strip over the inner band connection.
6. Affix the outer band to the outer bead, pulling the band tight to allow the bolts to slot into the clip of the band.
7. Once slotted, tighten the bolts using a 3/8" nut driver to tighten the outer band around the outer beads of the pipe.

NOTE: For outdoor installations, apply a bead of high-temperature sealant in the groove at the upper end of the outer band.

SYSTEM COMPONENTS

CUSTOM DIMENSIONS ARE AVAILABLE TO SUIT YOUR NEEDS IN EVEN AND ODD SIZES.

ADAPTER KIT (FLANGED)

PART NO. BKF

The Adapter Kit (Flanged) is used for securing a pipe to a flanged appliance outlet. Beam clamps are provided to connect the flanges, or the flange can be drilled in the field to match the appliance.

Includes one inner band and one seal ring to cover the gap between the inner and outer shells.

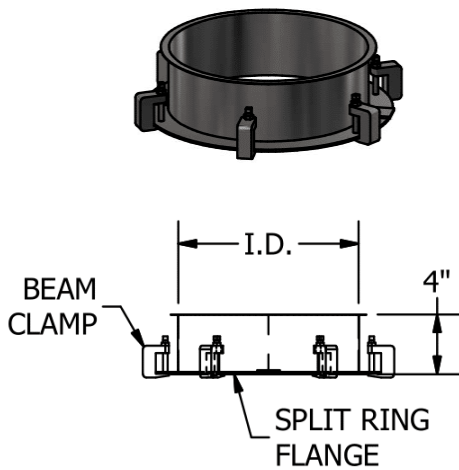

ADAPTER KIT (RAW)

PART NO. BKR

The Adapter Kit (Raw) is used for securing the pipe to an unflanged appliance outlet.

Includes one inner band and one seal ring to cover the gap between the inner and outer shells.

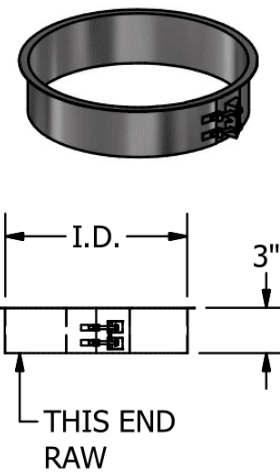

PART NO. BKF	
I.D.	CLAMPS
6"	3
8"	4
10"	5
12"	6
14"	7
16"	8
18"	9
20"	10
22"	11
24"	12
26"	13
28"	14
30"	15
32"	16
34"	17
36"	18
38"	19

PART NO. BKR	
I.D.	
6"	
8"	
10"	
12"	
14"	
16"	
18"	
20"	
22"	
24"	
26"	
28"	
30"	
32"	
34"	
36"	
38"	

SYSTEM COMPONENTS

CUSTOM DIMENSIONS ARE AVAILABLE TO SUIT YOUR NEEDS IN EVEN AND ODD SIZES.

STRAIGHT SECTION

PART NO. 18S, 29S, 47S AND 59S

Standard lengths are as follows:

Diameter 6" is 18", 29" and 47"

Diameters 8" to 24" are 18", 29", 47" and 59"

Diameters 26" to 38" are 18", 29" and 47"

Custom parts can be manufactured to any length over 8".

Includes one inner band, one outer band and one preinstalled gasket.

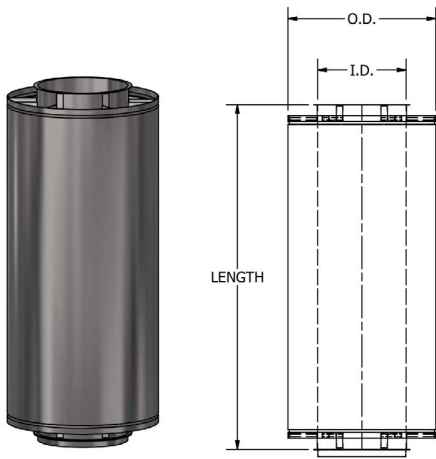

VARIABLE LENGTH SECTION

PART NO. 18VS, 29VS AND VS

The Variable Section adjusts to provide a fixed odd length between two sections. The minimum length is 5", the maximum is 18", 29" or 40". This part does not provide for thermal expansion.

Includes a liner, shell, slip joint and one inner band.

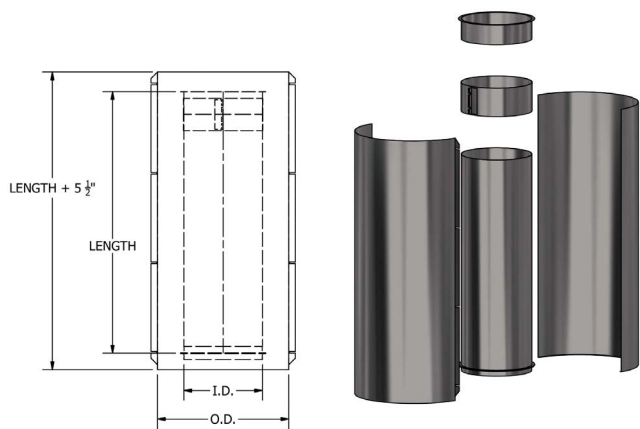

PART NO. 18S / 29S / 47S / 59S	
I.D.	O.D.
6"	14"
8"	16"
10"	18"
12"	20"
14"	22"
16"	24"
18"	26"
20"	28"
22"	30"
24"	32"
26"	34"
28"	36"
30"	38"
32"	40"
34"	42"
36"	44"
38"	46"

PART NO. 18VS / 29VS / VS	
I.D.	O.D.
6"	14"
8"	16"
10"	18"
12"	20"
14"	22"
16"	24"
18"	26"
20"	28"
22"	30"
24"	32"
26"	34"
28"	36"
30"	38"
32"	40"
34"	42"
36"	44"
38"	46"

SYSTEM COMPONENTS

CUSTOM DIMENSIONS ARE AVAILABLE TO SUIT YOUR NEEDS IN EVEN AND ODD SIZES.

90° GREASE TEE

PART NO. GT

The Grease Tee is a combination of a 90° Tee and a Tool-less Access Door, used to provide access into a grease duct system. The access door is located on one side of the main, while the internal flange collar is located on the branch. A circular dam is provided to prevent grease from running out of the duct when the cap is removed.

Includes two inner bands, two outer bands and one preinstalled gasket.

Note: When ordering, specify if the dam is in the main or tap.

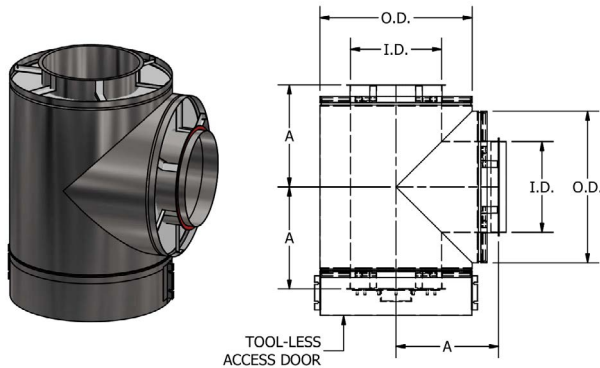

90° GREASE TEE (Branch)

PART NO. GTB

The Grease Tee (Branch) is a combination of a 90° Tee and a Tool-less Access Door, used to provide access into a grease duct system. The access door is located on the branch, while the internal flange collar is located on one side of the main. A circular dam is provided to prevent grease from running out of the duct when the cap is removed.

Includes two inner bands, two outer bands and one preinstalled gasket.

Note: When ordering, specify if the dam is in the main or tap.

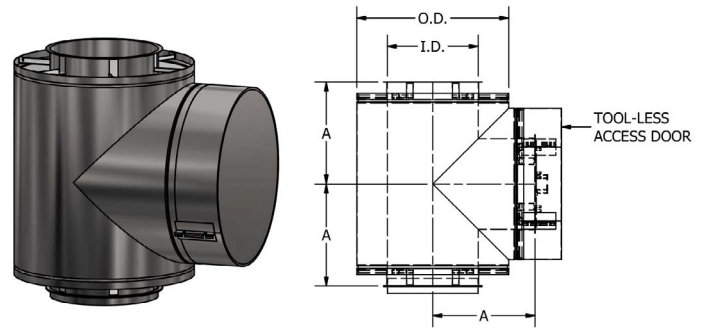

PART NO. GT	
I.D.	A
6"	10"
8"	11"
10"	12"
12"	13"
14"	14"
16"	15"
18"	16"
20"	17"
22"	18"
24"	19"
26"	20"
28"	21"
30"	22"
32"	23"
34"	24"
36"	25"
38"	26"

PART NO. GTB	
I.D.	A
6"	10"
8"	11"
10"	12"
12"	13"
14"	14"
16"	15"
18"	16"
20"	17"
22"	18"
24"	19"
26"	20"
28"	21"
30"	22"
32"	23"
34"	24"
36"	25"
38"	26"

SYSTEM COMPONENTS

CUSTOM DIMENSIONS ARE AVAILABLE TO SUIT YOUR NEEDS IN EVEN AND ODD SIZES.

90° GREASE TEE (Main)

PART NO. GTM

The Grease Tee (Main) is a combination of a 90° Tee and a Tool-less Access Door, used to provide access into a grease duct system. The access door is located on one side of the main, with the internal flange collar on the other. A circular dam is provided to prevent grease from running out of the duct when the cap is removed.

Includes two inner bands, two outer bands and one preinstalled gasket.

Note: When ordering, specify if the dam is in the main or tap.

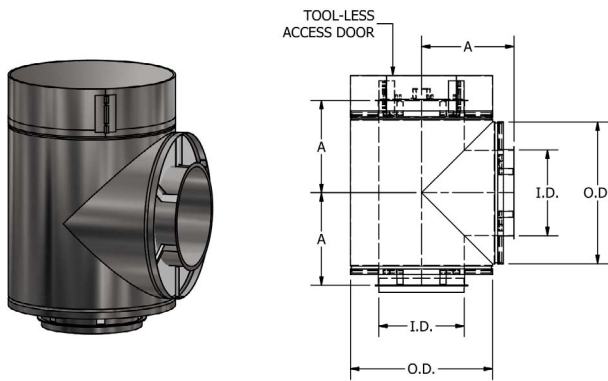

TAPERED INCREASER

PART NO. TI

The Tapered Increaser is used when a change in pipe diameter is required.

Includes one preinstalled gasket, one inner band and one outer band of both smaller and larger sizes.

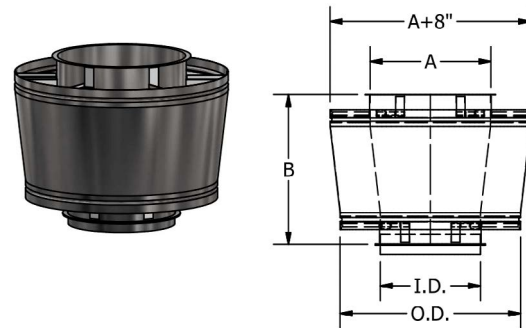

PART NO. GTM	
I.D.	A
6"	10"
8"	11"
10"	12"
12"	13"
14"	14"
16"	15"
18"	16"
20"	17"
22"	18"
24"	19"
26"	20"
28"	21"
30"	22"
32"	23"
34"	24"
36"	25"
38"	26"

PART NO. TI								
I.D.	A	B	A	B	A	B	A	B
6"	8"	15"	10"	18"	12"	21"	14"	24"
8"	10"	15"	12"	18"	14"	21"	16"	24"
10"	12"	15"	14"	18"	16"	21"	18"	24"
12"	14"	15"	16"	18"	18"	21"	20"	24"
14"	16"	15"	18"	18"	20"	21"	22"	24"
16"	18"	15"	20"	18"	22"	21"	24"	24"
18"	20"	15"	22"	18"	24"	21"	26"	24"
20"	22"	15"	24"	18"	26"	21"	28"	24"
22"	24"	15"	26"	18"	28"	21"	30"	24"
24"	26"	15"	28"	18"	30"	21"	32"	24"
26"	28"	15"	30"	18"	32"	21"	34"	24"
28"	30"	15"	32"	18"	34"	21"	36"	24"
30"	32"	15"	34"	18"	36"	21"	38"	24"
32"	34"	15"	36"	18"	38"	21"	40"	24"
34"	36"	15"	38"	18"	40"	21"	42"	24"
36"	38"	15"	40"	18"	42"	21"	44"	24"
38"	40"	15"	42"	18"	44"	21"	46"	24"

Available in odd sizes.
Call for odd diameter taper increaser information.

SYSTEM COMPONENTS

CUSTOM DIMENSIONS ARE AVAILABLE TO SUIT YOUR NEEDS IN EVEN AND ODD SIZES.

ECCENTRIC TAPERED INCREASER PART NO. ETI

The Eccentric Tapered In increaser is used when a change in pipe diameter is required and maintains an eccentric profile when it is necessary for the pipe to be flat on one side.

Includes one preinstalled gasket, one inner band and one outer band of both smaller and larger sizes.

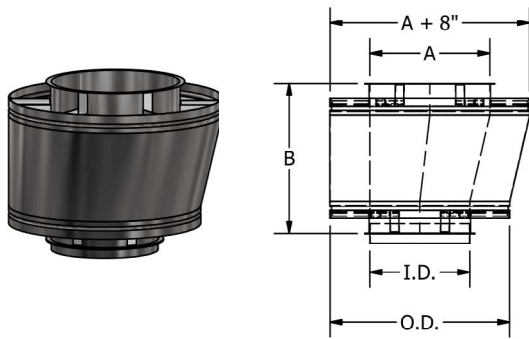

PART NO. ETI								
I.D.	A	B	A	B	A	B	A	B
6"	8"	15"	10"	18"	12"	21"	14"	24"
8"	10"	15"	12"	18"	14"	21"	16"	24"
10"	12"	15"	14"	18"	16"	21"	18"	24"
12"	14"	15"	16"	18"	18"	21"	20"	24"
14"	16"	15"	18"	18"	20"	21"	22"	24"
16"	18"	15"	20"	18"	22"	21"	24"	24"
18"	20"	15"	22"	18"	24"	21"	26"	24"
20"	22"	15"	24"	18"	26"	21"	28"	24"
22"	24"	15"	26"	18"	28"	21"	30"	24"
24"	26"	15"	28"	18"	30"	21"	32"	24"
26"	28"	15"	30"	18"	32"	21"	34"	24"
28"	30"	15"	32"	18"	34"	21"	36"	24"
30"	32"	15"	34"	18"	36"	21"	38"	24"
32"	34"	15"	36"	18"	38"	21"	40"	24"
34"	36"	15"	38"	18"	40"	21"	42"	24"
36"	38"	15"	40"	18"	42"	21"	44"	24"
38"	40"	15"	42"	18"	44"	21"	46"	24"

Available in odd sizes.
Call for odd diameter taper increaser information.

90° TEE PART NO. 90T

The 90° Tee is used to join horizontal and vertical sections, as well as to provide for the connection of drain or inspection fittings. Use either the drain tee cap or the end cap for closure of the unused opening.

Includes two preinstalled gaskets, two inner bands and two outer bands.

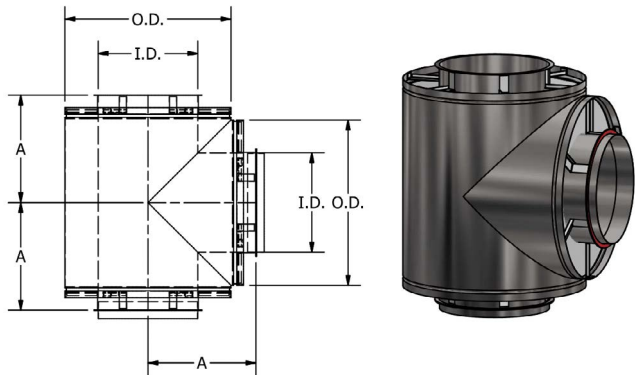

PART NO. 90T	
I.D.	A
6"	10"
8"	11"
10"	12"
12"	13"
14"	14"
16"	15"
18"	16"
20"	17"
22"	18"
24"	19"
26"	20"
28"	21"
30"	22"
32"	23"
34"	24"
36"	25"
38"	26"

SYSTEM COMPONENTS

CUSTOM DIMENSIONS ARE AVAILABLE TO SUIT YOUR NEEDS IN EVEN AND ODD SIZES.

ORIGINAL 90° TEE

PART NO. 090T

The Original 90° Tee is used to join horizontal and vertical sections, as well as to provide for the connection of drain or inspection fittings. Use either the drain tee cap or the end cap for closure of the unused opening.

Includes one preinstalled gasket, one inner band and one outer band.

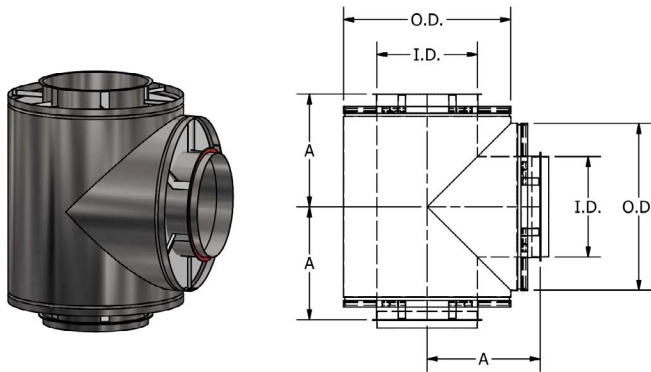

REDUCING 90° TEE

PART NO. R90T

The Reducing 90° Tee is used to join horizontal and vertical sections of different sizes, as well as to provide for the connection of drain or inspection fittings. Use either the drain tee cap or the end cap for closure of the unused opening. Specify the size of branch required.

Includes one preinstalled gasket, one inner band and outer band for larger and smaller openings.

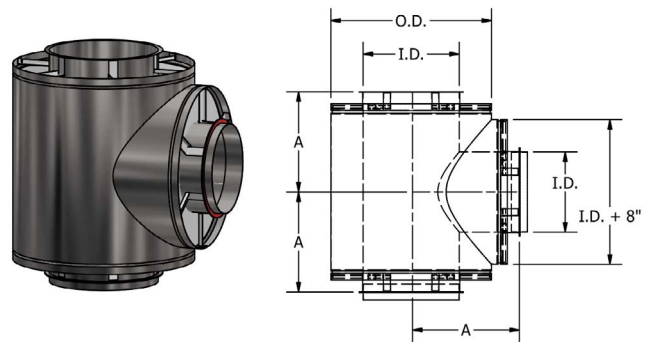

PART NO. 090T	
I.D.	A
6"	10 1/2"
8"	11 1/2"
10"	12 1/2"
12"	13 1/2"
14"	14 1/2"
16"	15 1/2"
18"	16 1/2"
20"	17 1/2"
22"	18 1/2"
24"	19 1/2"
26"	20 1/2"
28"	21 1/2"
30"	22 1/2"
32"	23 1/2"
34"	24 1/2"
36"	25 1/2"
38"	26 1/2"

PART NO. R90T	
I.D.	A
6"	10"
8"	11"
10"	12"
12"	13"
14"	14"
16"	15"
18"	16"
20"	17"
22"	18"
24"	19"
26"	20"
28"	21"
30"	22"
32"	23"
34"	24"
36"	25"
38"	26"

SYSTEM COMPONENTS

CUSTOM DIMENSIONS ARE AVAILABLE TO SUIT YOUR NEEDS IN EVEN AND ODD SIZES.

ORIGINAL REDUCING 90° TEE

PART NO. OR90T

The Original Reducing 90° Tee is used to join horizontal and vertical sections of different sizes, as well as to provide for the connection of drain or inspection fittings. Use either the drain tee cap or the end cap for closure of the unused opening. Specify the size of the branch required.

Includes one preinstalled gasket, one inner band and one outer band for larger and smaller openings.

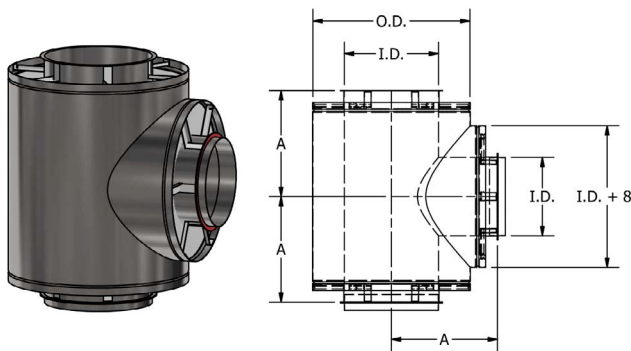

PART NO. OR90T	
I.D.	A
6"	10 1/2"
8"	11 1/2"
10"	12 1/2"
12"	13 1/2"
14"	14 1/2"
16"	15 1/2"
18"	16 1/2"
20"	17 1/2"
22"	18 1/2"
24"	19 1/2"
26"	20 1/2"
28"	21 1/2"
30"	22 1/2"
32"	23 1/2"
34"	24 1/2"
36"	25 1/2"
38"	26 1/2"

45° LATERAL TEE

PART NO. 45LT

The 45° Lateral Tee is used for low flow resistance entry into a stack or breeching.

Includes two preinstalled gaskets, two inner bands and two outer bands.

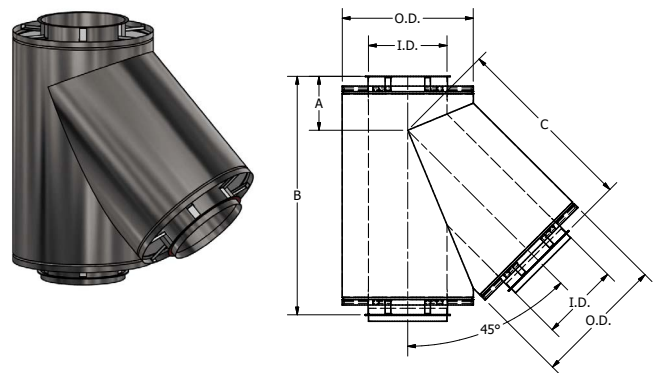

PART NO. 45LT			
I.D.	A	B	C
6"	7"	28"	21"
8"	7 3/8"	30 3/4"	23 3/8"
10"	7 3/4"	33 1/2"	25 3/4"
12"	8 1/4"	36 1/2"	28 1/4"
14"	8 5/8"	39 1/4"	30 5/8"
16"	9 1/16"	42 1/8"	33 1/16"
18"	9 1/2"	45"	35 1/2"
20"	9 7/8"	47 3/4"	37 7/8"
22"	10 5/16"	50 5/8"	40 5/16"
24"	10 3/4"	53 1/2"	42 3/4"
26"	11 1/8"	56 1/4"	45 1/8"
28"	11 9/16"	59 1/8"	47 9/16"
30"	12"	62"	50"
32"	12 3/8"	64 3/4"	52 3/8"
34"	12 3/4"	67 1/2"	54 3/4"
36"	13 3/16"	70 3/8"	57 3/16"
38"	13 5/8"	73 1/4"	59 5/8"

SYSTEM COMPONENTS

CUSTOM DIMENSIONS ARE AVAILABLE TO SUIT YOUR NEEDS IN EVEN AND ODD SIZES.

REDUCING 45° LATERAL TEE PART NO. R45LT

The Reducing 45° Lateral Tee is used for low flow resistance entry into a stack or breeching when the stack or breeching is a larger size. Specify the size of branch required.

Includes one preinstalled gasket, one inner band and one outer band for larger and smaller openings.

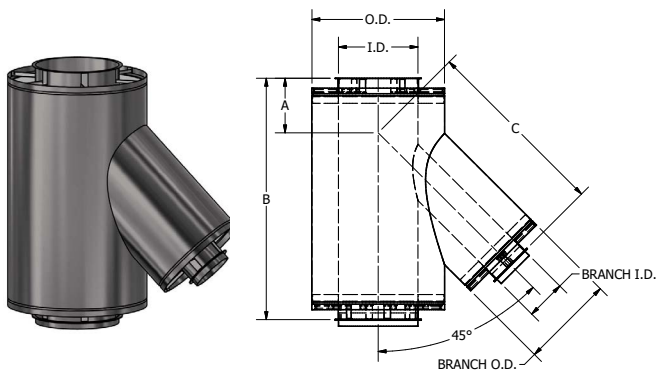

PART NO. R45LT			
I.D.	A	B	C
6"	7"	28"	21"
8"	7 3/8"	30 3/4"	23 3/8"
10"	7 3/4"	33 1/2"	25 3/4"
12"	8 1/4"	36 1/2"	28 1/4"
14"	8 5/8"	39 1/4"	30 5/8"
16"	9 1/16"	42 1/8"	33 1/16"
18"	9 1/2"	45"	35 1/2"
20"	9 7/8"	47 3/4"	37 7/8"
22"	10 5/16"	50 5/8"	40 5/16"
24"	10 3/4"	53 1/2"	42 3/4"
26"	11 1/8"	56 1/4"	45 1/8"
28"	11 9/16"	59 1/8"	47 9/16"
30"	12"	62"	50"
32"	12 3/8"	64 3/4"	52 3/8"
34"	12 3/4"	67 1/2"	54 3/4"
36"	13 3/16"	70 3/8"	57 3/16"
38"	13 5/8"	73 1/4"	59 5/8"

90° LATERAL TEE PART NO. 90LT

The 90° Lateral Tee is used to join horizontal and vertical sections with lower resistance, as well as to provide for the connection of drain or inspection fittings. Use either the drain tee cap or the end cap for closure of the unused opening.

Includes two preinstalled gaskets, two inner bands and two outer bands

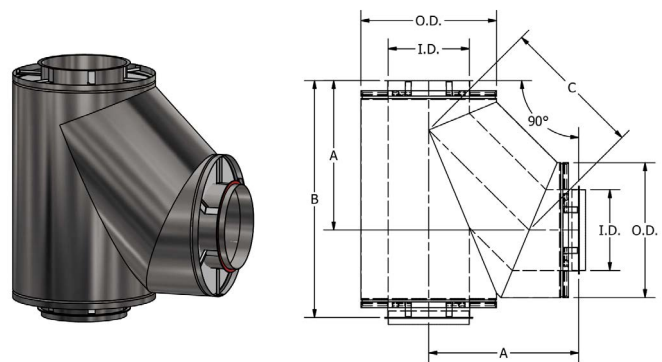

PART NO. 90LT			
I.D.	A	B	C
6"	6 1/16"	16 11/16"	26 11/16"
8"	6 1/2"	18 1/2"	29 1/2"
10"	6 15/16"	20 3/8"	32 5/16"
12"	7 5/16"	22 3/16"	35 3/16"
14"	7 3/4"	24"	38"
16"	8 3/16"	25 13/16"	40 13/16"
18"	8 9/16"	27 11/16"	43 5/8"
20"	9"	29 1/2"	46 1/2"
22"	9 3/8"	31 5/16"	49 5/16"
24"	9 13/16"	33 1/8"	52 1/8"

SYSTEM COMPONENTS

CUSTOM DIMENSIONS ARE AVAILABLE TO SUIT YOUR NEEDS IN EVEN AND ODD SIZES.

REDUCING 90° LATERAL TEE PART NO. R90LT

The Reducing 90° Lateral Tee is used to join horizontal and vertical sections of different sizes with lower resistance, as well as to provide for the connection of drain or inspection fittings. Use either the drain tee cap or the end cap for closure of the unused opening. Specify the size of branch required.

Includes one preinstalled gasket, one inner band and one outer band for larger and smaller openings.

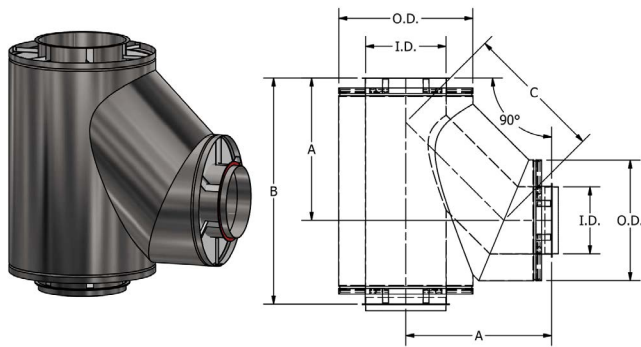

PART NO. R90LT			
I.D.	A	B	C
6"	6 1/16"	16 11/16"	26 11/16"
8"	6 1/2"	18 1/2"	29 1/2"
10"	6 15/16"	20 3/8"	32 5/16"
12"	7 5/16"	22 3/16"	35 3/16"
14"	7 3/4"	24"	38"
16"	8 3/16"	25 13/16"	40 13/16"
18"	8 9/16"	27 11/16"	43 5/8"
20"	9"	29 1/2"	46 1/2"
22"	9 3/8"	31 5/16"	49 5/16"
24"	9 13/16"	33 1/8"	52 1/8"

90° WYE PART NO. 90Y

The 90° Wye is used for joining runs where low flow resistance is desired. All openings must be the same size.

For connections to smaller diameter sections, use the tapered increaser in conjunction with the 90° wye.

Includes two preinstalled gaskets, two inner bands and two outer bands.

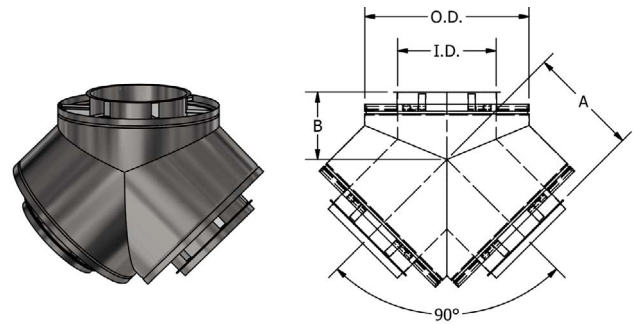

PART NO. 90Y		
I.D.	A	B
6"	10 1/2"	7"
8"	11 1/2"	7 13/32"
10"	12 1/2"	7 13/16"
12"	13 1/2"	8 7/32"
14"	14 1/2"	8 5/8"
16"	15 1/2"	9 1/16"
18"	16 1/2"	9 7/16"
20"	17 1/2"	9 7/8"
22"	18 1/2"	10 9/32"
24"	19 1/2"	10 23/32"
26"	20 1/2"	11 1/8"
28"	21 1/2"	11 17/32"
30"	22 1/2"	11 31/32"
32"	23 1/2"	12 3/8"
34"	24 1/2"	12 25/32"
36"	25 1/2"	13 3/16"
38"	26 1/2"	13 11/16"

SYSTEM COMPONENTS

CUSTOM DIMENSIONS ARE AVAILABLE TO SUIT YOUR NEEDS IN EVEN AND ODD SIZES.

90° ELBOW PART NO. 90L

The 90° Elbow is used when making a 90° change. The 90° elbow is available in 6" to 24" inner diameters. For a 90° directional change in diameters from 26" through 38", use two 45° elbows.

Includes one preinstalled gasket, one inner band and one outer band.

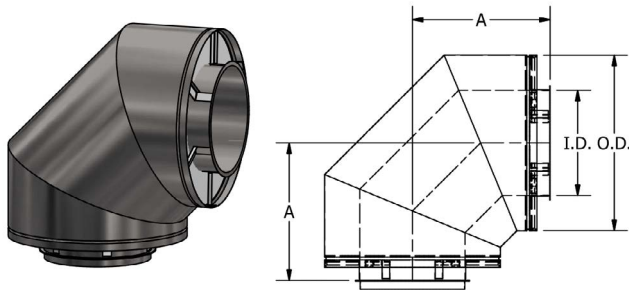

PART NO. 90L	
I.D.	A
6"	12 11/16"
8"	13 7/8"
10"	15 1/16"
12"	15 11/16"
14"	16 7/8"
16"	17 1/2"
18"	18 11/16"
20"	19 15/16"
22"	20 1/2"
24"	21 3/4"

ORIGINAL 90° ELBOW PART NO. 090L

The Original 90° Elbow is used when making a 90° change. The original 90° elbow is available in 6" to 24" diameters. For a 90° directional change in diameters from 26" through 38", use two 45° elbows.

Includes one preinstalled gasket, one inner band and one outer band.

Note: The Original 90° Elbow is a long sweep/large radius elbow compared to the 90° Elbow.

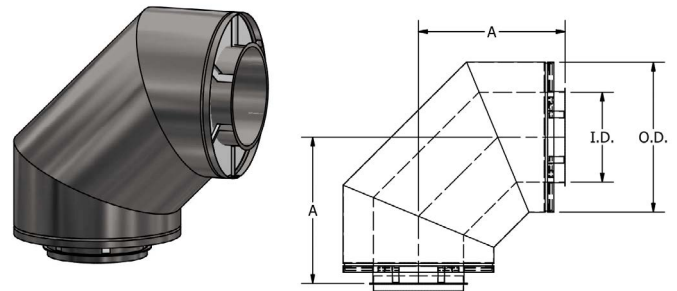

PART NO. 090L	
I.D.	A
6"	13 1/2"
8"	15 1/2"
10"	17 1/2"
12"	19 1/2"
14"	21 1/2"
16"	23 1/2"
18"	25 1/2"
20"	27 1/2"
22"	29 1/2"
24"	31 1/2"

SYSTEM COMPONENTS

CUSTOM DIMENSIONS ARE AVAILABLE TO SUIT YOUR NEEDS IN EVEN AND ODD SIZES.

45° ELBOW

PART NO. 45L

The 45° Elbow is used when a vertical or horizontal direction change of 45° is required.

Includes one preinstalled gasket, one inner band and one outer band.

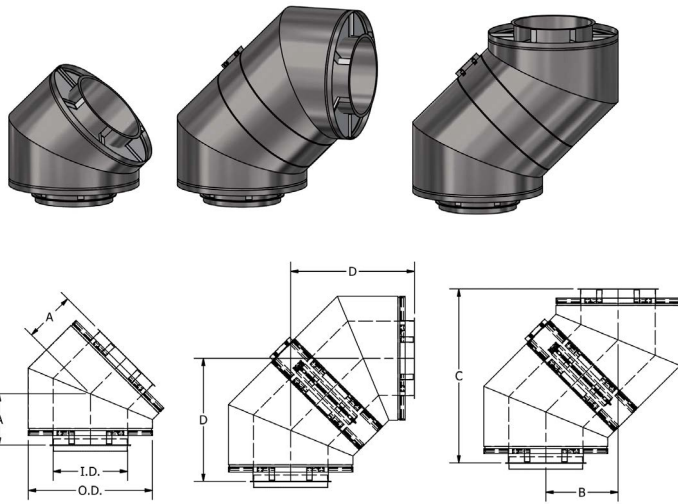

PART NO. 45L				
I.D.	A	B	C	D
6"	7"	9 29/32"	23 29/32"	16 29/32"
8"	7 3/8"	10 7/16"	25 3/16"	17 13/16"
10"	7 3/4"	11 3/64"	26 43/64"	18 55/64"
12"	8 1/4"	11 43/64"	28 11/64"	19 59/64"
14"	8 5/8"	12 13/64"	29 29/64"	20 53/64"
16"	9 1/16"	12 13/16"	30 15/16"	21 7/8"
18"	9 1/2"	13 7/16"	32 7/16"	22 15/16"
20"	9 7/8"	13 31/32"	33 23/32"	23 27/32"
22"	10 5/16"	14 37/64"	35 13/64"	24 57/64"
24"	10 3/4"	15 13/64"	36 45/64"	25 61/64"
26"	11 1/8"	15 47/64"	37 63/64"	26 55/64"
28"	11 9/16"	16 23/64"	39 31/64"	27 59/64"
30"	12"	16 7/8"	40 3/4"	28 13/16"
32"	12 3/8"	17 1/2"	42 1/4"	29 7/8"
34"	12 3/4"	18 1/32"	43 17/32"	30 25/32"
36"	13 3/16"	18 21/32"	45 1/32"	31 27/32"
38"	13 5/8"	19 17/64"	46 33/64"	32 57/64"

30° ELBOW

PART NO. 30L

The 30° Elbow is used when a vertical or horizontal direction change of 30° is required.

Includes one preinstalled gasket, one inner band and one outer band.

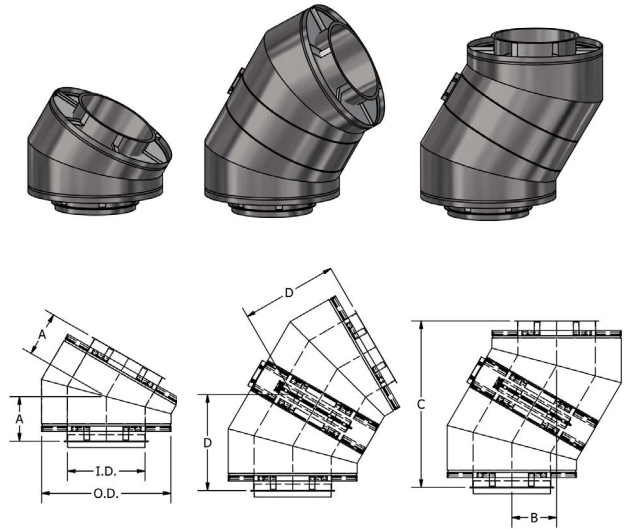

PART NO. 30L				
I.D.	A	B	C	D
6"	6 1/8"	6 1/8"	22 55/65"	13 13/64"
8"	6 3/8"	6 3/8"	23 51/64"	13 47/64"
10"	6 5/8"	6 5/8"	24 23/32"	14 9/32"
12"	6 15/16"	6 15/16"	25 57/64"	14 61/64"
14"	7 3/16"	7 3/16"	26 23/64"	15 31/64"
16"	7 7/16"	7 7/16"	27 3/4"	16 1/32"
18"	7 3/4"	7 3/4"	28 59/64"	16 45/64"
20"	8"	8"	29 55/64"	17 15/64"
22"	8 1/4"	8 1/4"	30 51/64"	17 23/32"
24"	8 1/2"	8 1/2"	31 23/32"	18 5/16"
26"	8 3/4"	8 3/4"	32 21/32"	18 55/64"
28"	9 1/16"	9 1/16"	33 53/64"	19 17/32"
30"	9 5/16"	9 5/16"	34 3/4"	20 1/6"
32"	9 9/16"	9 9/16"	35 11/16"	20 39/64"
34"	9 7/8"	9 7/8"	36 55/64"	21 9/32"
36"	10 1/8"	10 1/8"	37 25/32"	21 13/16"
38"	10 3/8"	10 3/8"	38 23/32"	22 23/64"

SYSTEM COMPONENTS

CUSTOM DIMENSIONS ARE AVAILABLE TO SUIT YOUR NEEDS IN EVEN AND ODD SIZES.

END CAP PART NO. EC

The End Cap is used to close an unused tee opening and to provide a means of accessing the interior of the system for inspection and cleaning.

Includes one inner band.

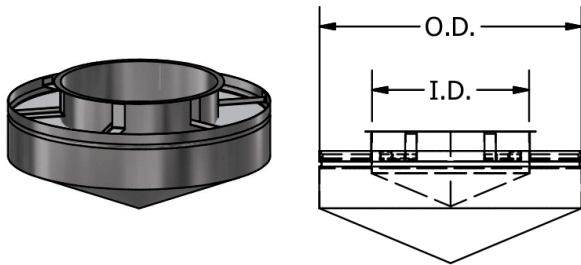

DRAIN TEE CAP PART NO. DTC

The Drain Tee Cap is used to close an unused tee opening and to provide a drain at the base of a vertical chimney.

Includes one inner band.

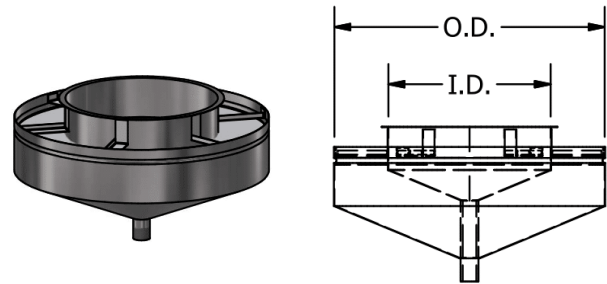

PART NO. EC	
I.D.	O.D.
6"	14"
8"	16"
10"	18"
12"	20"
14"	22"
16"	24"
18"	26"
20"	28"
22"	30"
24"	32"
26"	34"
28"	36"
30"	38"
32"	40"
34"	42"
36"	44"
38"	46"

PART NO. DTC	
I.D.	O.D.
6"	14"
8"	16"
10"	18"
12"	20"
14"	22"
16"	24"
18"	26"
20"	28"
22"	30"
24"	32"
26"	34"
28"	36"
30"	38"
32"	40"
34"	42"
36"	44"
38"	46"

SYSTEM COMPONENTS

CUSTOM DIMENSIONS ARE AVAILABLE TO SUIT YOUR NEEDS IN EVEN AND ODD SIZES.

DRAIN SECTION

PART NO. DS

The Drain Section is used to drain rainwater and condensation from within the stack. The NPT nipple should be connected to a suitable drain.

Includes one preinstalled gasket, one inner band and one outer band.

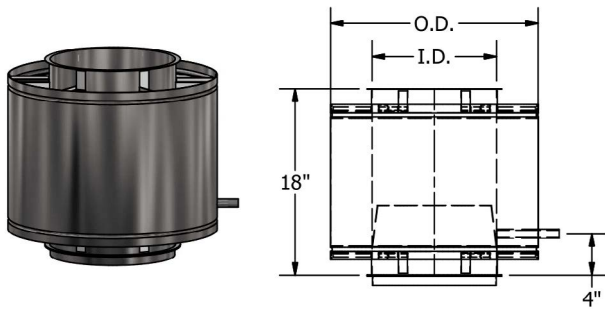

HORIZONTAL DRAIN

PART NO. HD

The Horizontal Drain is used to drain rainwater and condensation from within the stack. The NPT nipple should be connected to a suitable drain.

Includes one preinstalled gasket, one inner band and one outer band.

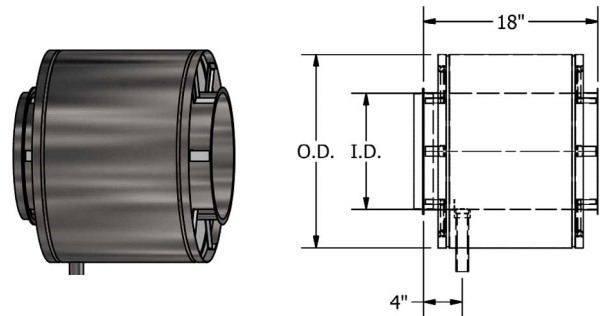

PART NO. DS	
I.D.	O.D.
6"	14"
8"	16"
10"	18"
12"	20"
14"	22"
16"	24"
18"	26"
20"	28"
22"	30"
24"	32"
26"	34"
28"	36"
30"	38"
32"	40"
34"	42"
36"	44"
38"	46"

PART NO. HD	
I.D.	O.D.
6"	14"
8"	16"
10"	18"
12"	20"
14"	22"
16"	24"
18"	26"
20"	28"
22"	30"
24"	32"
26"	34"
28"	36"
30"	38"
32"	40"
34"	42"
36"	44"
38"	46"

SYSTEM COMPONENTS

CUSTOM DIMENSIONS ARE AVAILABLE TO SUIT YOUR NEEDS IN EVEN AND ODD SIZES.

NOZZLE SECTION

PART NO. NS

The Nozzle Section is used to attach plumbing equipment to grease ducts.

Includes one preinstalled gasket, one inner band and one outer band.

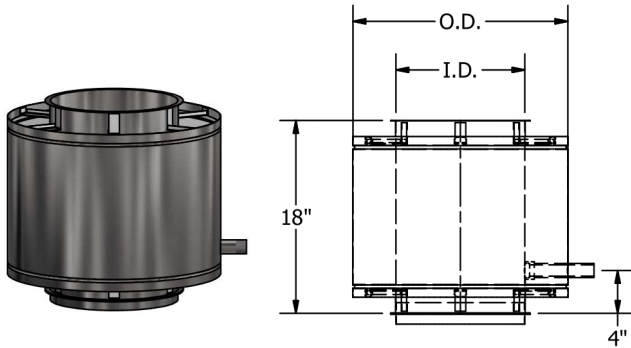

BASE DRAIN SECTION

PART NO. BD

The Base Drain Section provides a bottom closure and drain attachment for base-supported chimneys. The NPT nipple should be connected to a suitable drain.

Includes one inner and one outer band.

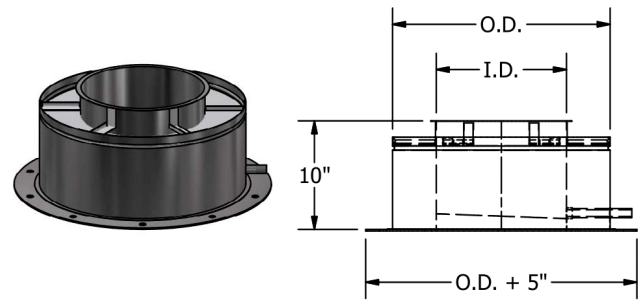

PART NO. NS	
I.D.	O.D.
6"	14"
8"	16"
10"	18"
12"	20"
14"	22"
16"	24"
18"	26"
20"	28"
22"	30"
24"	32"
26"	34"
28"	36"
30"	38"
32"	40"
34"	42"
36"	44"
38"	46"

PART NO. BD	
I.D.	O.D.
6"	14"
8"	16"
10"	18"
12"	20"
14"	22"
16"	24"
18"	26"
20"	28"
22"	30"
24"	32"
26"	34"
28"	36"
30"	38"
32"	40"
34"	42"
36"	44"
38"	46"

SYSTEM COMPONENTS

CUSTOM DIMENSIONS ARE AVAILABLE TO SUIT YOUR NEEDS IN EVEN AND ODD SIZES.

FLASHING

PART NO. FL

The Flashing is used in conjunction with the rain collar to seal roof penetrations. This part is designed for flat roofs. Custom-pitched flashings are available upon request.

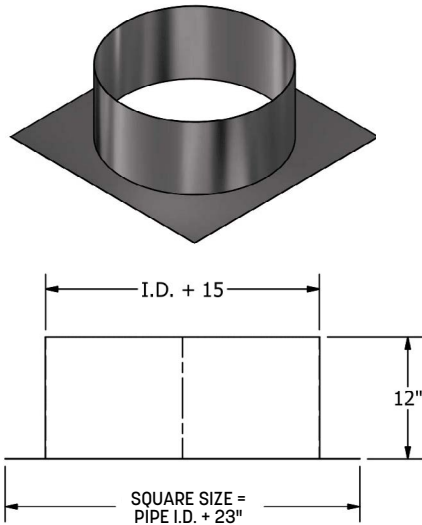

RAIN COLLAR

PART NO. RC

The Rain Collar is used in conjunction with the flashing to seal roof penetrations.

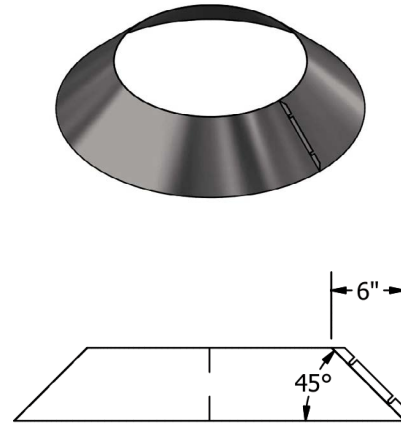

RAIN CAP

PART NO. CC

The Rain Cap is used at stack terminations to prevent water from entering the flue. A drain should be used at the base of stacks to drain water that may be blown into the flue.

Includes one preinstalled gasket, one inner band and one closure ring to seal the outer shell joint.

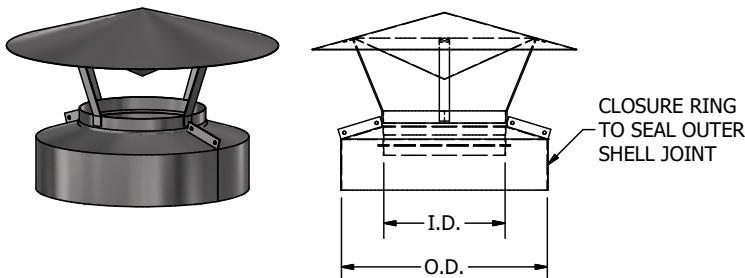

SYSTEM COMPONENTS

CUSTOM DIMENSIONS ARE AVAILABLE TO SUIT YOUR NEEDS IN EVEN AND ODD SIZES.

HOOD TRANSITIONS

The transition between the grease hood or listed ventilator and the Schebler duct is made using a transition constructed of 20-gauge or heavier stainless steel. The transition can be single-wall or double-wall, air or ceramic fiber insulated. The transition should be attached to the hood with a liquid-tight weld or by the bolt method described in NFPA 96 or IMC 2000.

If the transition is manufactured by others, Schebler can supply a boiler kit (part no. BKF) with a single or double flange for welding to the top of the transition.

Note: Hood transitions are to be coordinated with the design team to meet the project's unique needs.

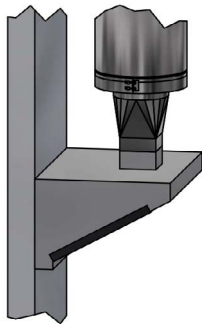

ISOMETRIC VIEW

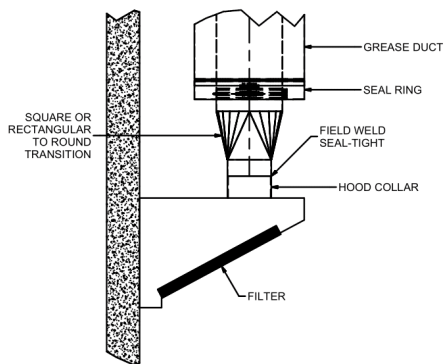

ROOF TRANSITIONS

The grease duct shall terminate with a minimum of 10 ft. (3.048 m) of clearance from the outlet to adjacent buildings, property lines and air intakes. Where space limitations absolutely prevent a 10 ft. (3.048 m) horizontal separation from an air intake, a vertical separation will be acceptable with the exhaust outlet being a minimum of 3 ft. (0.93 m) above any air intake located within 10 ft. (3.048 m) horizontally.

The exhaust will be directed up and away from the surface of the roof and a minimum of 40" (1.02 m) above the roof surface. Schebler offers a fan adapter (part no. FA) that can be used for connecting the flue to a curb-mounted rooftop fan.

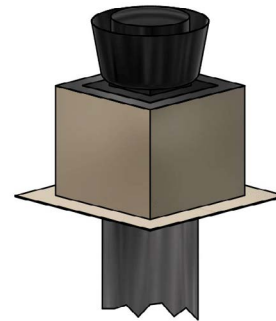

ISOMETRIC VIEW

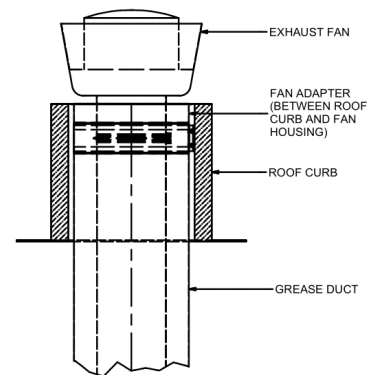

SYSTEM COMPONENTS

CUSTOM DIMENSIONS ARE AVAILABLE TO SUIT YOUR NEEDS IN EVEN AND ODD SIZES.

FIRESTOP PART NO. FS

The Firestop is used when penetrating through a fire-rated floor or wall.

Includes one closure seal ring, two cover ring halves, one 12" wide insulation strip, one 4" wide insulation strip and Hilti Firestop Putty.

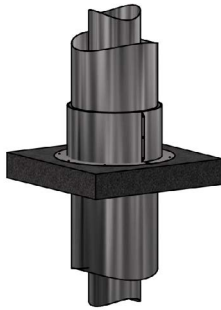

ISOMETRIC VIEW

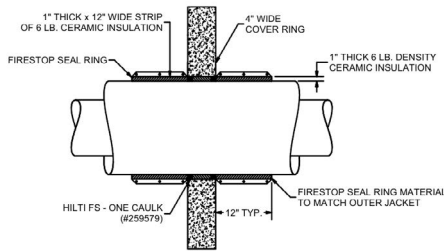

WALL PENETRATION

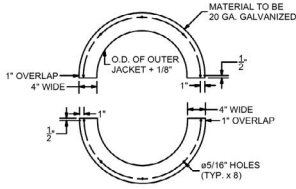

COVER RING

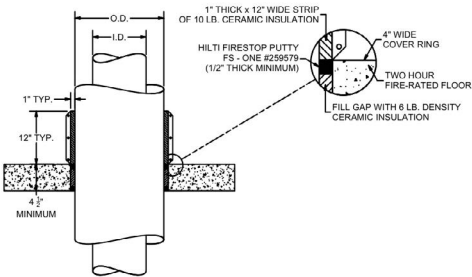

FLOOR PENETRATION

FAN ADAPTER PART NO. FA

The Fan Adapter is used to attach a grease duct to an exhaust fan or kitchen hood.

Includes one preinstalled gasket, one inner band and one outer band.

Note: Plenum boxes are available for multiple-fan systems.

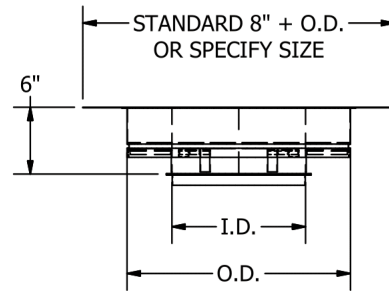
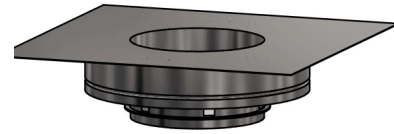

PART NO. FA	
I.D.	O.D.
6"	14"
8"	16"
10"	18"
12"	20"
14"	22"
16"	24"
18"	26"
20"	28"
22"	30"
24"	32"
26"	34"
28"	36"
30"	38"
32"	40"
34"	42"
36"	44"
38"	46"

SYSTEM COMPONENTS

CUSTOM DIMENSIONS ARE AVAILABLE TO SUIT YOUR NEEDS IN EVEN AND ODD SIZES.

SQUARE-TO-ROUND TRANSITIONS

The Square-to-Round Transitions are used when connecting to appliances with square or rectangular outlets. They can be raw for field welding, flanged for field drilling and bolting or with bolt-patterned flanges.

Note: This part will be custom-built/coordinated with the design team for each application.

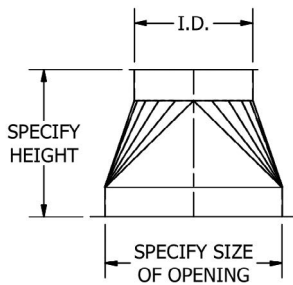
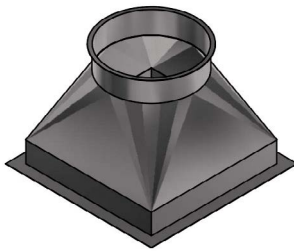

SUPPORT PLATE

PART NO. SP

The Support Plate is the primary load-carrying member of the chimney assembly. This part is designed to support (B) (See chart below) feet of vertical chimney section, as well as provide fixed points in breeching runs.

Includes two half-outer bands.

Note: This part must be placed at the connection of two flue sections.

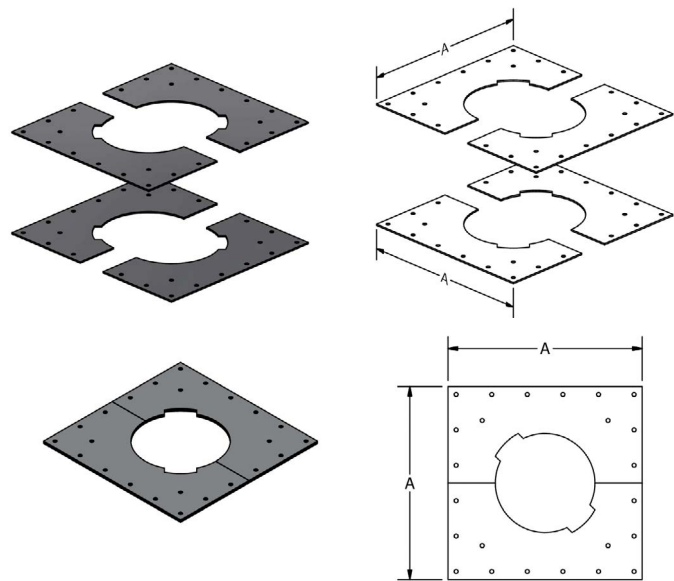

PART NO. SP		
I.D.	A	B (FT)
6"	18"	178'
8"	20"	173'
10"	22"	169'
12"	24"	159'
14"	26"	155'
16"	28"	150'
18"	30"	145'
20"	32"	141'
22"	34"	136'
24"	36"	132'
26"	38"	127'
28"	40"	122'
30"	42"	118'
32"	44"	113'
34"	46"	108'
36"	48"	104'

SYSTEM COMPONENTS

CUSTOM DIMENSIONS ARE AVAILABLE TO SUIT YOUR NEEDS IN EVEN AND ODD SIZES.

WALL SUPPORT

PART NO. WS

The Wall Support is used to provide chimney support along a wall. The wall support will maintain the required clearance to combustible structures when properly installed and can support (C) (See chart below) feet of vertical chimney.

Includes two half-outer bands.

Note: This part must be placed at the connection of two flue sections.

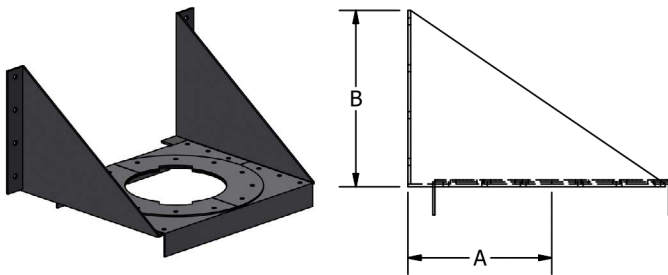

PART NO. WS		
I.D.	A	B
6"	9"	7 3/8"
8"	11"	7 7/8"
10"	12"	8 1/8"
12"	13"	8 3/8"
14"	14"	8 5/8"
16"	15"	9"
18"	17"	9 7/16"
20"	18"	9 3/4"
22"	20"	10 1/4"
24"	21"	10 9/16"
26"	23"	11"
28"	24"	11 5/16"
30"	26"	11 13/16"
32"	27"	12 1/8"
34"	29"	12 5/8"
36"	30"	12 15/16"
38"	32"	13 7/16"

GUY SECTION

PART NO. GS

The Guy Section is used when the chimney extends beyond the vertical limits above the roof line. The guy section should be connected to guy wires or a rigid guying structure.

Includes two half-outer bands.

Note: This part must be placed at the connection of two flue sections.

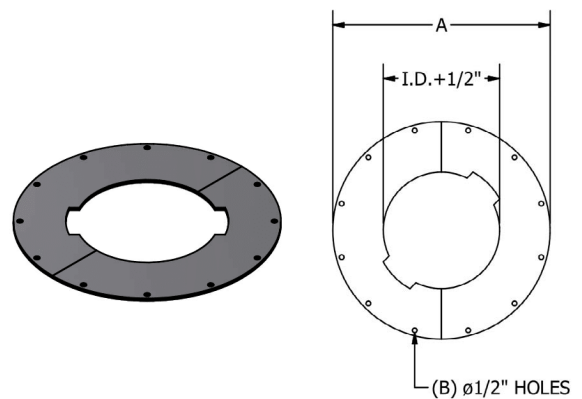

PART NO. GS		
I.D.	A	B
6"	17 1/8"	12"
8"	19"	12"
10"	21"	12"
12"	23"	12"
14"	25"	12"
16"	27"	12"
18"	29"	12"
20"	31"	12"
22"	33"	16"
24"	35"	16"
26"	37"	16"
28"	39"	16"
30"	41"	20"
32"	43"	20"
34"	45"	20"
36"	47"	20"
38"	49"	24"

SYSTEM COMPONENTS

CUSTOM DIMENSIONS ARE AVAILABLE TO SUIT YOUR NEEDS IN EVEN AND ODD SIZES.

FLOOR/ROOF GUIDE

PART NO. FRG

The Floor/Roof Guide is used at the penetration of floors and roofs to guide the chimney. This part is designed to absorb lateral loads only. It will not support vertical chimney sections.

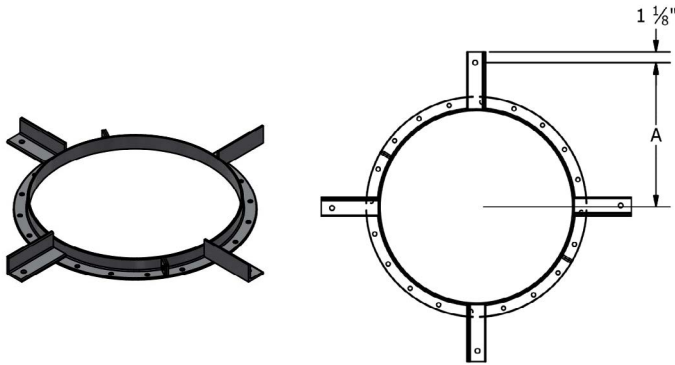

PART NO. FRG	
I.D.	A
6"	12 3/8"
8"	13 3/8"
10"	14 3/8"
12"	15 3/8"
14"	16 3/8"
16"	17 3/8"
18"	18 3/8"
20"	19 3/8"
22"	20 3/8"
24"	21 3/8"
26"	22 3/8"
28"	23 3/8"
30"	24 3/8"
32"	25 3/8"
34"	26 3/8"
36"	27 3/8"
38"	28 3/8"

WALL GUIDE

PART NO. WG

The Wall Guide is used to guide long vertical runs placed adjacent to walls. This part maintains proper clearance to combustibles when properly installed.

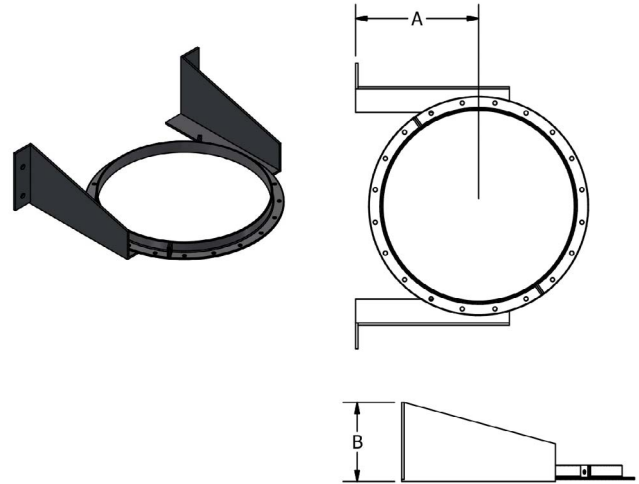

PART NO. WG		
I.D.	A	B
6"	9"	7 3/8"
8"	11"	7 7/8"
10"	12"	8 1/8"
12"	13"	8 3/8"
14"	14"	8 5/8"
16"	15"	9"
18"	17"	9 7/16"
20"	18"	9 3/4"
22"	20"	10 1/4"
24"	21"	10 9/16"
26"	23"	11"
28"	24"	11 5/16"
30"	26"	11 13/16"
32"	27"	12 1/8"
34"	29"	12 5/8"
36"	30"	12 15/16"
38"	32"	13 7/16"

SYSTEM COMPONENTS

CUSTOM DIMENSIONS ARE AVAILABLE TO SUIT YOUR NEEDS IN EVEN AND ODD SIZES.

FULL RING PART NO. FR

The Full Ring is used to guide horizontal and vertical runs. The part is simply bolted around the outer shell and then rigidly connected to the building structure.

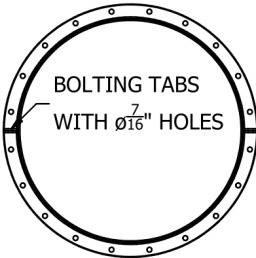
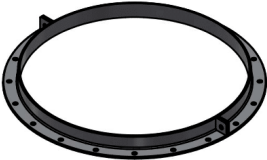

HANGER PART NO. HG

The Hanger is used to support long horizontal runs and is placed under the flue and then supported by rods connecting to the building structure.

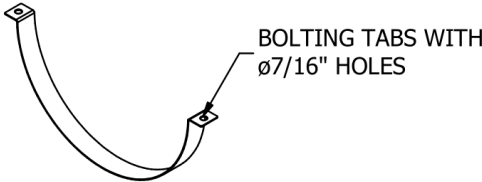

SYSTEM COMPONENTS

CUSTOM DIMENSIONS ARE AVAILABLE TO SUIT YOUR NEEDS IN EVEN AND ODD SIZES.

FYREGUARD® WEIGHT CHART

Part Description	Part No.	INSIDE DIAMETER (INCHES)																
		6"	8"	10"	12"	14"	16"	18"	20"	22"	24"	26"	28"	30"	32"	34"	36"	38"
14" to 17" Adjustable	18AL	25 lbs	29	33	37	42	46	50	54	59	63	67	71	88	92	97	102	121
16" to 21" Adjustable	22AL	29 lbs	34	39	44	49	54	59	64	69	74	79	84	103	109	114	120	142
20" to 29" Adjustable	30AL	37 lbs	43	50	56	63	69	76	82	89	95	101	108	134	141	149	156	183
27½" to 44" Adjustable	45AL	52 lbs	61	71	80	89	98	107	117	126	135	144	153	191	202	213	223	259
29" Straight Section	29S	34 lbs	40	46	51	57	63	69	75	81	87	93	99	122	129	136	143	167
30 Degree Elbow	30L	16 lbs	19	22	26	30	39	44	49	55	60	66	72	78	85	92	99	120
45 Degree Lateral Elbow	45L	17 lbs	21	26	30	35	47	53	60	67	74	82	90	99	108	116	126	153
45 Degree Tee	45LT	44 lbs	56	70	85	101	140	163	187	213	241	270	301	334	368	403	440	532
47" Straight Section	47S	52 lbs	61	71	80	89	98	107	117	126	135	144	153	191	202	213	223	259
59" Straight Section	59S	-	76	87	99	110	122	133	144	156	167	-	-	-	-	-	-	-
90 Degree Elbow	90L	26 lbs	34	44	55	67	95	112	131	151	173	-	-	-	-	-	-	-
90 Degree Grease Tee	90GT	35 lbs	44	53	63	73	99	113	128	144	161	178	197	216	236	257	279	338
90 Degree Wye	90Y	35 lbs	43	52	62	73	98	112	127	143	159	177	195	215	235	256	277	335
90 Degree Tee	90T	31 lbs	38	46	55	64	86	98	111	125	139	154	170	187	204	222	241	292
Abrupt In increaser	AI	9 lbs	10	12	14	16	18	20	21	23	25	27	29	31	33	34	36	45
Base Drain	BD	25 lbs	30	34	38	42	46	51	55	59	63	67	72	82	87	91	96	110
Adapter Kit Flanged	BKF	9 lbs	10	12	14	16	18	20	21	23	25	27	29	31	33	34	36	45
Adapter Kits Raw	BKR	6 lbs	7	8	9	10	11	12	13	14	16	17	18	19	20	21	22	30
Drain Section	DS	24 lbs	28	32	36	40	44	48	52	56	60	64	68	84	88	93	98	116
Drain Tee Cap	DTC	7 lbs	8	9	10	12	14	15	17	19	22	24	26	38	42	45	49	58
End Cap	EC	6 lbs	7	8	9	11	13	14	16	18	21	23	25	37	41	44	48	57
Fan Adapter	FA	20 lbs	23	26	29	33	36	39	43	46	50	53	56	65	69	72	76	90
Flashing	FL	15 lbs	16	18	19	21	22	24	25	27	29	30	32	34	35	37	39	40
Floor/Roof Guide	FRG	12 lbs	15	16	17	18	19	24	25	27	27	30	30	32	33	34	35	36
Full Ring	FR	6 lbs	9	10	11	12	13	18	19	21	21	24	24	26	27	28	29	30
Guy Section	GS	20 lbs	23	27	30	33	36	40	43	46	50	53	56	59	63	66	69	76
Half Ring	HR	3 lbs	5	5	5	6	6	9	10	10	11	12	12	13	13	14	15	15
Horizontal Drain	HD	24 lbs	28	32	36	40	44	48	52	56	60	64	68	84	88	93	98	116
Nozzle Section	NS	24 lbs	28	32	36	40	44	48	52	56	60	64	68	84	88	93	98	116
Rain Cap	CC	11 lbs	14	16	19	22	25	28	32	35	39	43	47	51	60	66	72	80
Rain Collar	RC	5 lbs	6	6	7	7	8	8	9	9	10	10	11	11	12	12	13	13
Support Plate	SP	31 lbs	36	42	47	53	58	64	70	76	99	107	114	122	130	138	146	186
Tapered In creaser	TI	28 lbs	32	37	42	47	60	66	71	77	82	88	93	99	105	110	116	136
Top Section	TS	6 lbs	7	8	9	10	11	12	13	14	15	16	17	18	22	23	24	28
Variable Section	VS	52 lbs	61	71	80	89	98	107	117	126	135	144	153	191	202	213	223	259
Wall Guide	WG	15 lbs	20	21	23	25	27	34	37	40	42	46	48	52	54	57	60	63
Wall Support	WS	49 lbs	60	70	81	91	103	118	132	149	179	199	215	236	254	277	295	346

All weights shown above are actual weights; for shipping weights, multiply by 1.25



SAMPLE SPECIFICATION

FyreGuard[®]

The factory-built modular grease duct system is laboratory tested and listed in accordance with Underwriters Laboratories Standard UL 2221 Classified for **zero clearance** to combustibles. Sections shall bear the UL listing mark and the cUL listing mark for Canada. Sections shall be sealed with banded flanges and a silicone rubber gasket.

Inner shell material shall be type 304 stainless steel. Inner shell thickness shall be 0.036" for 5" to 36" diameter systems. All inner shell seams shall be full penetration-welded the entire length of the pipe section. Riveted, tack or spot-welded seams are not permitted.

Outer shell material shall be 430 stainless steel with a thickness of 0.034" for 5" to 36" diameter systems. All outer shell seams shall be full penetration-welded the entire length of the pipe section. Riveted, tack or spot-welded seams are not permitted.

Between the inner and outer shells, there shall be a minimum 4" of 1,800°F-rated low-conductivity ceramic fiber insulation. The insulation is to be securely attached to the inner shell with steel straps and insulating pins welded to the inner shell. Stainless steel centering clips shall be welded to the outer shell to maintain the 4" spacing and ensure the concentricity of the shells.

Breeching and chimney sections, when installed according to the manufacturer's instructions, shall comply with national safety standards and building codes. Stacks terminating above a roof must terminate as required by code or NFPA 211.

Chimney sections exposed to atmospheric conditions shall be protected by a minimum of one base coat and one finish coat of heat-resistant paint after installation. Outer shells of type 304 or 316 stainless steel need not be painted.

SCHERER

LIMITED LIFETIME WARRANTY GREASE DUCT APPLICATIONS

The Schebler® Company warrants its FyreGuard® model products installed in grease duct applications against defects in material and workmanship for the entire duration the product is incorporated and used in its original installation when said product is properly installed per Schebler's design and current installation instructions or specifications and is properly connected to a code-compliant commercial kitchen ventilation system for cooking appliances. This warranty is subject to all terms and conditions described in The Schebler Company's Standard Terms and Conditions of Sale.

THE SCHEBLER COMPANY'S STANDARD TERMS AND CONDITIONS OF SALE.

The Schebler Company will, at its sole discretion, either repair or replace any defective product covered by this Limited Warranty at no charge, provided, however, that Buyer shall be responsible for all costs of removal, shipping and reinstallation of the product.

Furthermore, this warranty does not apply to any system component not manufactured by The Schebler Company and installed as part of the UL system. Repair or replacement of products provided under this Limited Warranty are similarly warranted for the remainder of the original warranty term. This limited warranty is extended solely to the original owner, subject to the satisfaction of the following conditions:

1. System sizing and design have been performed by Schebler personnel, and the design parameters provided to The Schebler Company by the responsible engineer were and are accurately representative of the system's operating conditions.
2. The undamaged components have been correctly installed in accordance with the Schebler system design and sizing and installation instructions published by The Schebler Company.
3. Proper precautions were taken to prevent damage to the grease duct during the cleaning of the system, including not using improper solvents or chemicals, which may also cause damage.
4. The Schebler Company has supplied the entire grease duct system, from the connection to the commercial cooking appliance to the termination of the grease duct.
5. Prior to start-up and thereafter, exposed aluminized steel surfaces were protected with a minimum of one base coat of primer and one finish of heat-resistant paint at all times.

The Schebler Company makes no other warranty, whether expressed or implied. This warranty shall be the sole and exclusive remedy of any Buyer, whether in contract, tort or otherwise. UNDER NO CIRCUMSTANCES SHALL THE SCHEBLER COMPANY BE LIABLE FOR ANY INCIDENTAL OR CONSEQUENTIAL DAMAGE OR COMMERCIAL LOSS OR FROM ANY OTHER LOSS OR DAMAGE EXCEPT AS SET FORTH HEREIN. The Schebler Company assumes no liability for any damages resulting in whole or part from misuse, improper installation or inadequate maintenance of the system or component part thereof, nor assumes or authorizes any other person or entity to assume on its behalf any other liability in connection with the sale of its products.

FyreGuard®

ZERO-CLEARANCE GREASE DUCT FROM SCHEBLER

FyreGuard® zero-clearance grease ducts mean important advantages for food service fire safety. These include 4" of insulation, **zero clearance** to combustibles, 2-hour fire rating and no need for a fire-rated chase. All Schebler prefabricated systems and engineered stacks are known for the value they provide through unmatched dimensional accuracy and detailed draft calculations. These translate into fast project completion, lowered installation costs and satisfied customers.

From hospitals to restaurants, from school cafeterias to residential buildings, quality grease ducts make a world of difference in safety and affordability. Since Schebler was founded in 1895, we have fabricated high-quality, innovative products designed and built with expert craftsmanship and backed by impeccable support. Contact Schebler for more information about our chimney solutions, including help with custom engineering and design solutions.

Made in America by a Team of Dedicated Employee-Owners
FIND YOUR LOCAL SCHEBLER CHIMNEY SYSTEMS DISTRIBUTOR



5665 Fenno Rd.
Bettendorf, IA 52722

563.359.0110

scheblerchimney.com