



Model P1

**PREFABRICATED
STAINLESS STEEL VENT**

DELIVERING THE CERTAINTY
OF DOUBLE-WALL,
UL LISTED VENTING



MODEL P1

PREFABRICATED STAINLESS STEEL VENT

OUR P SERIES CHIMNEYS ARE THE HIGHEST-QUALITY GENERAL-PURPOSE VENTS AVAILABLE.

Part of our UL listed P Series, the double-wall Model P1 is designed and built with one inch of insulation between the liner and the shell for use in venting appliances.

LISTING

The Schebler Model P1 chimney and exhaust system is listed by Underwriters Laboratories Inc. (UL) under file number MH17739 in the United States and Canada for the following uses. It also has the Underwriters Laboratories mark for Canada (cUL).

UL 103

A 1,400°F chimney, a 1,000°F Building Heating Appliance Chimney for positive pressures to 60" WC for high-temperature applications.

UL 103HT*

A Building Heating Appliance Chimney suitable for exposures to 2,100°F flue gases for a 10-minute duration.

UL 2561

A 1,400°F Building Heating Appliance Chimney for positive pressures to 60" WC intended for venting flue gases at a temperature not exceeding 1,400°F under continuous operating conditions, from building-heating appliances and other low-heat appliances.

UL 1978

Use for grease exhaust duct serving commercial cooking appliance hoods.

*For diameters 5" to 24" I.D.

The system is also approved by the New York City Department of Buildings for use in New York City. MEA # 227-94-M.



SYSTEM CONCEPT

The Model P1 is a modular, double-wall, prefabricated exhaust system with 1" of insulation for use in venting appliances that require a positive, neutral or negative draft exhaust system. Sections are provided in lightweight, easy-to-handle lengths and connected with the RapidLock® Connection System with high-temperature sealant. Straight sections, expansion joints, tees, elbows and support devices are offered, allowing a complete exhaust system to be assembled using standard components.

SURROUNDINGS

Model P1 chimneys are suitable for use with building heating appliances and other low-heat appliances as described in the Chimney Selection chart of the National Fire Protection Association Standard Number 211, which produce flue exhaust gases not exceeding 1,400°F under continuous operation or 2,100°F under intermittent operation. These chimneys are to be installed as required for metal chimneys. They are not to be enclosed within combustible construction. An unenclosed chimney may be placed adjacent to walls of combustible construction at the clearances specified.

COMPLETE LINE OF FITTINGS AND SIZES AVAILABLE

The Model P1 chimney system is available in even and odd diameters, ranging from 5" to 48". A complete line of straight sections, expansion joints, tees, elbows, rain caps, roof penetration components and support members is available. In addition to the standard components, virtually any conceivable fitting is available as a special-order item.

SUPPORT LIMITS

Support plates and wall supports are utilized to support the weight of the chimney and to provide a fixed point to allow proper operation of expansion joints. In horizontal runs, supports should be placed adjacent to fittings not otherwise supported. See the individual part description for allowable support charts.

MATERIAL AVAILABLE

The Model P1 is available in a variety of materials, allowing the proper material selection for your specific application. The standard product features a 304 stainless steel liner and a 430 stainless steel outer shell. For greater corrosion resistance, 316 stainless steel is available for the liner and 304 or 316 stainless steel for the outer shell.

For most applications, the standard 304 stainless steel inner and 430 stainless steel outer material selections are sufficient. For boilers firing oils heavier than No. 2 fuel oil, use 316 stainless steel for the inner shell.

MATERIAL THICKNESS

The standard 304 stainless steel inner shell thickness is 0.036" for 5" to 36" diameter systems and 0.048" for 38" to 48" diameter systems. Standard 430 stainless steel outer shell thickness is 0.028" for 5" to 36" diameter systems and 0.048" for 38" to 48" diameter systems.

TESTS PERFORMED

The Model P1 has endured rigorous tests by Underwriters Laboratories. Just a few of the tests performed are:

STRUCTURAL TESTS

The support plates and wall supports have been physically tested to carry a load four times that allowed by our listing.

WIND LOAD TESTS

Loads equivalent to 110 mph wind have been applied to the chimney with acceptable results.

SKIN TEMPERATURE RISE TESTS

The chimney has been subjected to a series of burn tests at temperatures up to 1,800°F. The purpose of these tests is to determine safe clearances from the chimney wall to combustible materials.

RAIN TESTS

The rain caps have been tested to ensure an unsatisfactory amount of water does not enter the rain cap.

SCHEBLER VALUE

FAST PROJECT COMPLETION

- Trouble-free installations/detailed instructions
- No on-site welding

MAXIMUM STRENGTH/LONG LIFE

- Unmatched dimensional accuracy for secure joint connections
- Fully welded liners and shells
- Unequaled support limits

COMPLETE SYSTEM DESIGN

- CAD drawings
- 3D design solutions
- Complete BOM
- System sizing

SPECIAL FITTINGS

- Customized components are available to meet the needs of your specific project



OPERATING TEMPERATURES AND CLEARANCES CHART

The Model P1 has been tested and listed for continuous use at both 1,000°F and 1,400°F to 2,100°F intermittent with gas, liquid and solid fuel appliances. In addition, the Model P1 is suitable for use as a grease duct at the following clearances to combustible materials. The clearances shown are from the shell to combustibles.

P1 CLEARANCE TO COMBUSTIBLES		
Section Inside Diameter	1,000°F (560°C) Chimney*	1,400°F (760°C) Chimney
5"-14"	1" (25mm)	1" (25mm)
15"-20"	2" (51mm)	2" (51mm)
21"-24"	3" (76mm)	3" (76mm)
25"-29"	4" (102mm)	4" (102mm)
30"-34"	5" (127mm)	5" (127mm)
35"-39"	6" (152mm)	6" (152mm)
40"-44"	7" (178mm)	7" (178mm)
45"-48"	8" (203mm)	8" (203mm)

*Building Heating Appliance Chimney

Section Inside Diameter	Type HT Building Heating Appliance/Chimney Application
5"-12"	1" (25mm)
13"-24"	2" (51mm)

Section Inside Diameter	Grease Duct
5"-10"	4" (102mm)
11"-16"	6" (152mm)
17"-20"	7" (178mm)
21"-24"	8" (203mm)
25"-28"	9" (229mm)
29"-32"	10" (254mm)
33"-48"	15" (381mm)

Clearance to non-combustible materials for all diameters and applications is 1" (25mm).

PART NUMBERS

All standard parts manufactured by Schebler are identified by a part number that describes their makeup and function.

The part numbers are made up as follows:

1. The first series is the model designation: PA, P1, P2, P2A, P4 or SW.
2. This is followed by the part name. For example, 47S, 90T or CC.
3. Next is the part's internal diameter in inches, such as 06, 12 or 24.
4. Last is the liner/shell material designation.

For example, the part number for an 8" ID, Model P1, 47" long straight section with a 304 stainless steel liner and 430 stainless steel shell is P1-47S-08N.

CODE	LINER / SHELL MATERIAL
A	304 / Aluminized
B	316 / Aluminized
C	304 / 304 or all 304
D	304 / 316
E	316 / 316 or all 316
F	Galvanized
G	Aluminized
H	Painted Carbon Steel
N	304 / 430
P	316 / 430
Q	430
S	316 / 304

JOINT ASSEMBLY

Note: Wipe the inner bands and flanges clean prior to assembly.

Steps:

1. Apply a continuous bead of proper sealant, covering one of the 1/2" flanges of the two parts being joined.
2. Fully fill the vee groove of the inner band with the proper sealant.
3. Join the flanged ends of the two sections together.
4. Install the inner band around the flanges and rotate the flange bolt into the corresponding notch of the clip and tighten both bolts.
5. Tap around the inner band with a rawhide mallet and retighten the flange bolts until they bottom out to ensure a tight joint.
6. Place the outer band over the space between the outer shells of the adjoining sections. The flanges on the outer band fit into the grooves on the shells.
7. Rotate the flange bolt into the corresponding notch of the clip and tighten both bolts evenly until secure. For outdoor installations, apply a bead of S600 sealant in the groove at the upper end of the outer band.

SEALANT

Schebler offers three types of sealant: S600, S2000 and S2001. The S600 is used for applications with flue gas temperatures up to 600°F (315°C). This includes most boilers and water heaters. The S2000 is used for grease duct systems. S2001 is used for installations operating under positive pressure, such as generator exhaust.



SYSTEM COMPONENTS

CUSTOM DIMENSIONS ARE AVAILABLE TO SUIT YOUR NEEDS IN EVEN AND ODD SIZES.

ADAPTER KIT (FLANGED)

PART NO. BKF

The Adapter Kit (Flanged) is used for securing a pipe to a flanged appliance outlet. Beam clamps are provided for the connection of the flanges, or the flange can be drilled in the field to match the appliance.

Includes one inner band and one seal ring to cover the gap between the inner and outer shells.

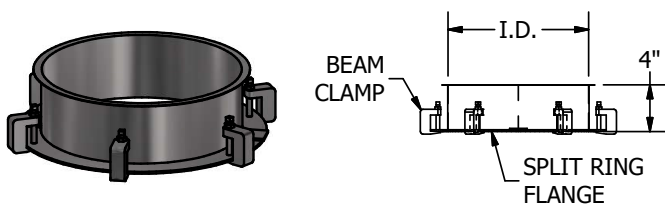

ADAPTER KIT (RAW)

PART NO. BKR

The Adapter Kit (Raw) is used for securing a pipe to an unflanged appliance outlet.

Includes one inner band and one seal ring to cover the gap between the inner and outer shells.

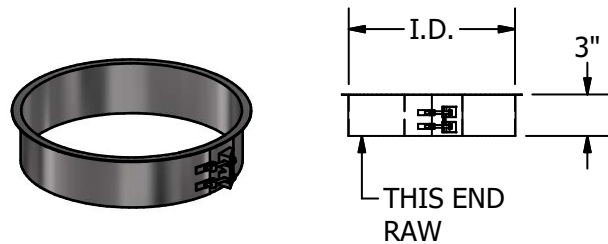

PART NO. BKF	
I.D.	CLAMPS
6"	3
8"	4
10"	5
12"	6
14"	7
16"	8
18"	9
20"	10
22"	11
24"	12
26"	13
28"	14
30"	15
32"	16
34"	17
36"	18
38"	19
40"	20
42"	21
44"	22
46"	23
48"	24

SYSTEM COMPONENTS

CUSTOM DIMENSIONS ARE AVAILABLE TO SUIT YOUR NEEDS IN EVEN AND ODD SIZES.

NOZZLE SECTION

PART NO. NS

The Nozzle Section includes a 1" NPT connection to be used as a test port.

Includes one inner band and one outer band.

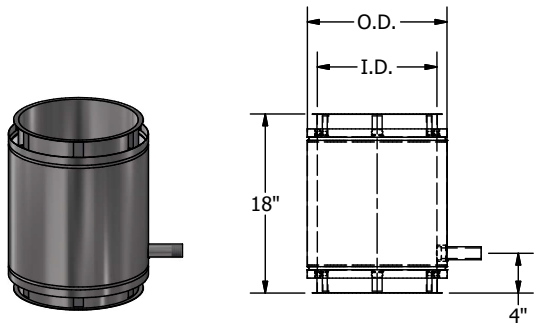

PART NO. NS	
I.D.	O.D.
6"	8"
8"	10"
10"	12"
12"	14"
14"	16"
16"	18"
18"	20"
20"	22"
22"	24"
24"	26"
26"	28"
28"	30"
30"	32"
32"	34"
34"	36"
36"	38"
38"	40"
40"	42"
42"	44"
44"	46"
46"	48"
48"	50"

STRAIGHT SECTION

PART NO. 18S, 29S, 47S AND 59S

Standard lengths are as follows:

Diameters 5" to 7" are 18", 29" and 47"

Diameters 8" to 24" are 18", 29", 47" and 59"

Diameters 25" to 48" are 18", 29" and 47"

Custom parts can be manufactured to any length over 8".

Includes one inner band and one outer band.

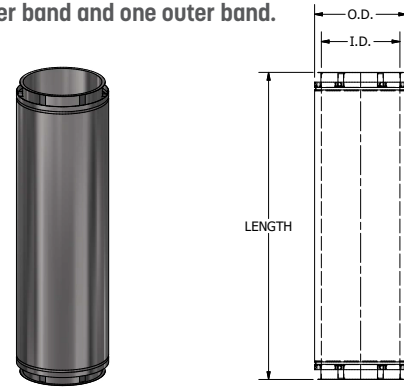

PART NO. 18S / 29S / 47S / 59S	
I.D.	O.D.
6"	8"
8"	10"
10"	12"
12"	14"
14"	16"
16"	18"
18"	20"
20"	22"
22"	24"
24"	26"
26"	28"
28"	30"
30"	32"
32"	34"
34"	36"
36"	38"
38"	40"
40"	42"
42"	44"
44"	46"
46"	48"
48"	50"

SYSTEM COMPONENTS

CUSTOM DIMENSIONS ARE AVAILABLE TO SUIT YOUR NEEDS IN EVEN AND ODD SIZES.

ADJUSTABLE LENGTH

PART NO. 18AL, 22AL, 30AL AND 45AL

The Adjustable Length is used to provide adjustment during installation, as well as to compensate for thermal expansion between fixed points.

Adjustment in length available for each part is as follows:

18AL is 14" to 17"

22AL is 16" to 21"

30AL is 20" to 29"

45AL is 27 1/2" to 44"

Includes one inner band and one outer band.

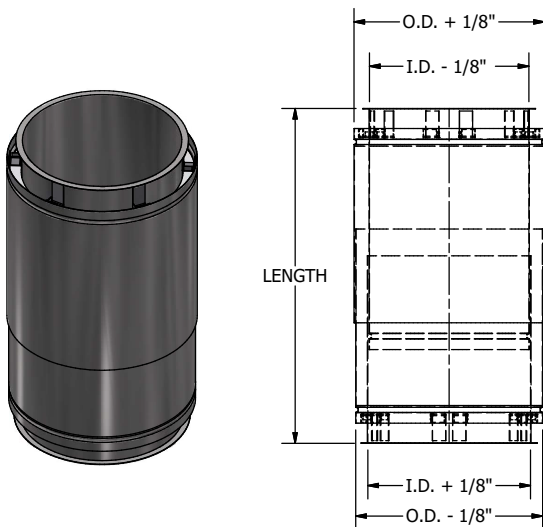

VARIABLE LENGTH SECTION

PART NO. 18VS, 29VS AND VS

The Variable Section adjusts to provide a fixed odd length between two sections.

The minimum length is 5" and the maximums are 18", 29" or 40".

This part does not provide for thermal expansion.

Includes liner, shell, slip joint and one inner band.

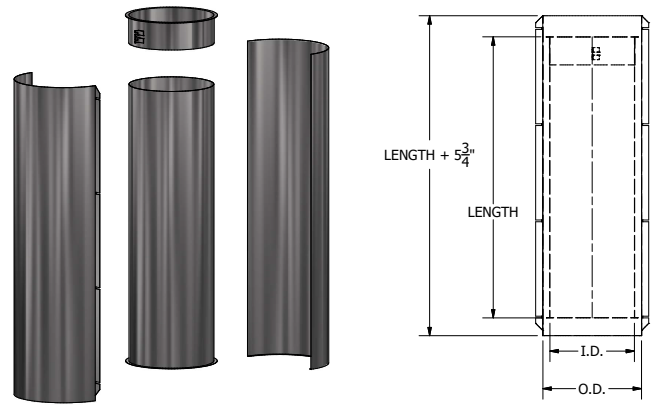

PART NO. 18VS / 29VS / VS

I.D.	O.D.
6"	8"
8"	10"
10"	12"
12"	14"
14"	16"
16"	18"
18"	20"
20"	22"
22"	24"
24"	26"
26"	28"
28"	30"
30"	32"
32"	34"
34"	36"
36"	38"
38"	40"
40"	42"
42"	44"
44"	46"
46"	48"
48"	50"

SYSTEM COMPONENTS

CUSTOM DIMENSIONS ARE AVAILABLE TO SUIT YOUR NEEDS IN EVEN AND ODD SIZES.

BELLOWS SECTION

PART NO. BS

The Bellows Section is designed to compensate for thermal expansion, up to 3".

This part is recommended for diesel engines and turbine exhaust systems.

Includes liner, shell and one inner band.

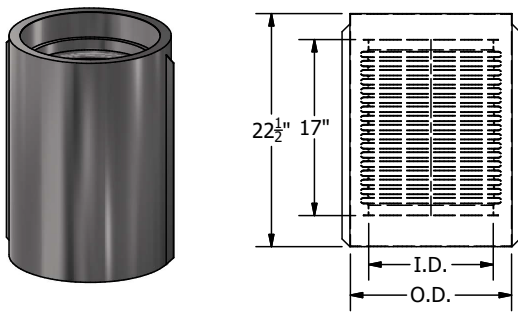

PART NO. BS	
I.D.	O.D.
6"	8"
8"	10"
10"	12"
12"	14"
14"	16"
16"	18"
18"	20"
20"	22"
22"	24"
24"	26"
26"	28"
28"	30"
30"	32"
32"	34"
34"	36"
36"	38"
38"	40"
40"	42"
42"	44"
44"	46"
46"	48"
48"	50"

ABRUPT INCREASER

PART NO. AI

The Abrupt Increaser is used to connect two sections of different diameters in a shorter space than a tapered increaser.

Includes one inner band of larger and smaller sizes and one seal ring.

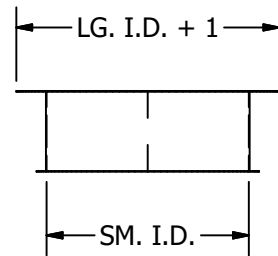
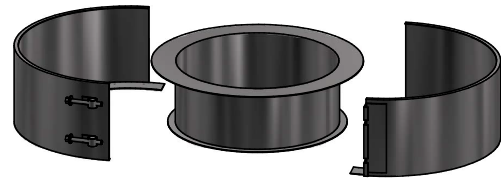

SYSTEM COMPONENTS

CUSTOM DIMENSIONS ARE AVAILABLE TO SUIT YOUR NEEDS IN EVEN AND ODD SIZES.

TAPERED INCREASER

PART NO. TI

The Tapered Increaser is used when a change in pipe diameter is required.

Includes one inner band and one outer band of both smaller and larger sizes.

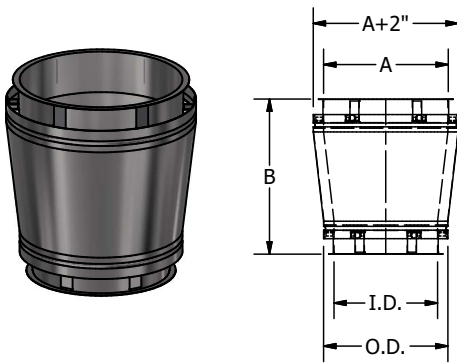

ECCENTRIC TAPERED INCREASER

PART NO. ETI

The Eccentric Tapered Increaser is used when a change in pipe diameter is required and maintains an eccentric profile when it is necessary for the pipe to be flat on one side.

Includes one inner band and one outer band of both smaller and larger sizes.

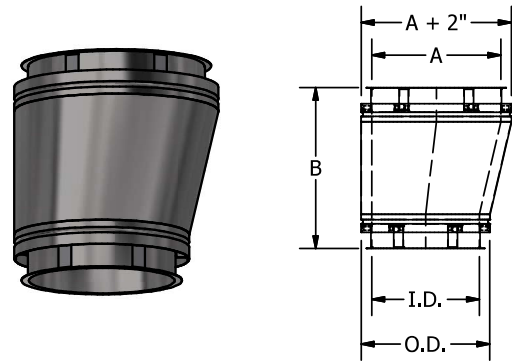

PART NO. TI / ETI

I.D.	A	B	A	B	A	B	A	B
6"	8"	15"	10"	18"	12"	21"	14"	24"
8"	10"	15"	12"	18"	14"	21"	16"	24"
10"	12"	15"	14"	18"	16"	21"	18"	24"
12"	14"	15"	16"	18"	18"	21"	20"	24"
14"	16"	15"	18"	18"	20"	21"	22"	24"
16"	18"	15"	20"	18"	22"	21"	24"	24"
18"	20"	15"	22"	18"	24"	21"	26"	24"
20"	22"	15"	24"	18"	26"	21"	28"	24"
22"	24"	15"	26"	18"	28"	21"	30"	24"
24"	26"	15"	28"	18"	30"	21"	32"	24"
26"	28"	15"	30"	18"	32"	21"	34"	24"
28"	30"	15"	32"	18"	34"	21"	36"	24"
30"	32"	15"	34"	18"	36"	21"	38"	24"
32"	34"	15"	36"	18"	38"	21"	40"	24"
34"	36"	15"	38"	18"	40"	21"	42"	24"
36"	38"	15"	40"	18"	42"	21"	44"	24"
38"	40"	15"	42"	18"	44"	21"	46"	24"
40"	42"	15"	44"	18"	46"	21"	48"	24"
42"	44"	15"	46"	18"	48"	21"	-	-
44"	46"	15"	48"	18"	-	-	-	-
46"	48"	15"	-	-	-	-	-	-
48"	-	-	-	-	-	-	-	-

Available in odd sizes. Call for odd diameter taper increaser information.

SYSTEM COMPONENTS

CUSTOM DIMENSIONS ARE AVAILABLE TO SUIT YOUR NEEDS IN EVEN AND ODD SIZES.

45° LATERAL TEE

PART NO. 45LT

The 45° Lateral Tee is used for low flow resistance entry into a stack or breeching.

Includes two inner bands and two outer bands.

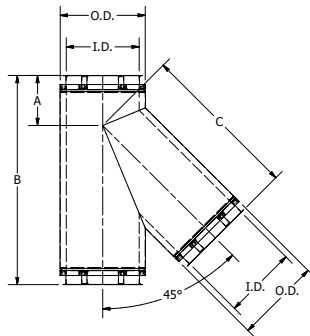
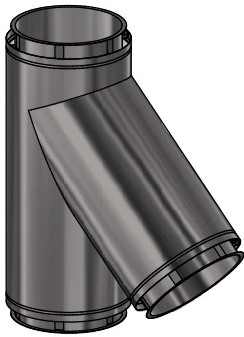

REDUCING 45° LATERAL TEE

PART NO. R45LT

The Reducing 45° Lateral Tee is used for low flow resistance entry into a stack or breeching when the stack or breeching is a larger size.

Specify the size of the branch required.

Includes one inner band and one outer band for larger and smaller openings.

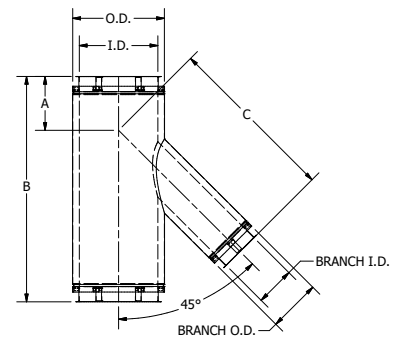

PART NO. 45LT / R45LT

I.D.	A	B	C
6"	7"	26"	19"
8"	7 3/8"	28 3/4"	21 3/8"
10"	7 3/4"	31 1/2"	23 3/4"
12"	8 1/4"	34 1/2"	26 1/4"
14"	8 5/8"	37 1/4"	28 5/8"
16"	9 1/16"	40 1/8"	31 1/16"
18"	9 1/2"	43"	33 1/2"
20"	9 7/8"	45 3/4"	35 7/8"
22"	10 5/16"	48 5/8"	38 5/16"
24"	10 3/4"	51 1/2"	40 3/4"
26"	11 1/8"	54 1/4"	43 1/8"
28"	11 9/16"	57 1/8"	45 9/16"
30"	12"	60"	48"
32"	12 3/8"	62 3/4"	50 3/8"
34"	12 3/4"	65 1/2"	52 3/4"
36"	13 3/16"	68 3/8"	55 3/16"
38"	13 5/8"	71 1/4"	57 5/8"
40"	14"	74"	60"
42"	14 7/16"	76 7/8"	62 7/16"
44"	14 7/8"	79 3/4"	64 7/8"
46"	15 1/4"	82 1/2"	67 1/4"
48"	15 11/16"	85 3/8"	69 11/16"

SYSTEM COMPONENTS

CUSTOM DIMENSIONS ARE AVAILABLE TO SUIT YOUR NEEDS IN EVEN AND ODD SIZES.

90° TEE

PART NO. 90T

The 90° Tee is used to join horizontal and vertical sections, as well as to provide for the connection of drain or inspection fittings. Use either the drain tee cap or the end cap for the closure of the unused opening.

Includes two inner bands and two outer bands.

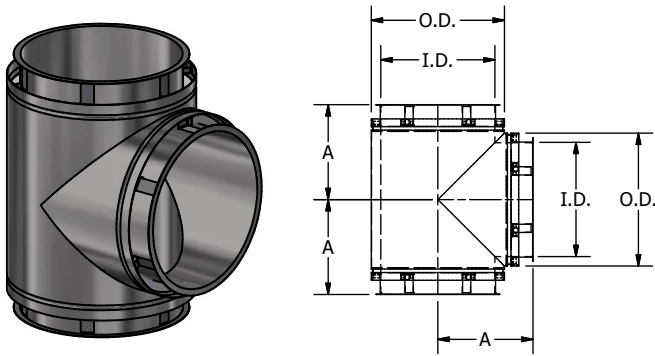

PART NO. 90T	
I.D.	A
6"	7"
8"	8"
10"	9"
12"	10"
14"	11"
16"	12"
18"	13"
20"	14"
22"	15"
24"	16"
26"	17"
28"	18"
30"	19"
32"	20"
34"	21"
36"	22"
38"	23"
40"	24"
42"	25"
44"	26"
46"	27"
48"	28"

ORIGINAL 90° TEE

PART NO. 090T

The Original 90° Tee is used to join horizontal and vertical sections, as well as to provide for the connection of drain or inspection fittings. Use either the drain tee cap or the end cap for the closure of the unused opening.

Includes two inner bands and two outer bands.

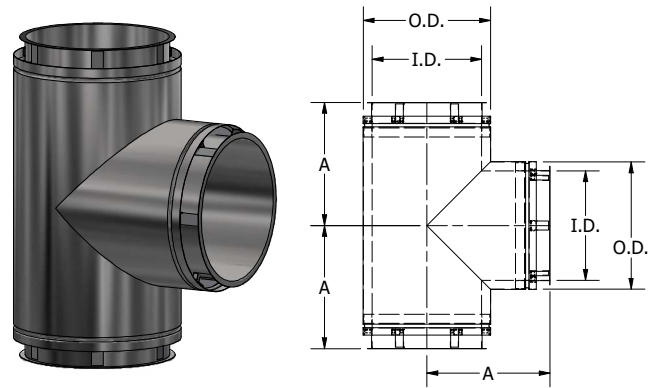

PART NO. 090T	
I.D.	A
6"	10 1/2"
8"	11 1/2"
10"	12 1/2"
12"	13 1/2"
14"	14 1/2"
16"	15 1/2"
18"	16 1/2"
20"	17 1/2"
22"	18 1/2"
24"	19 1/2"
26"	20 1/2"
28"	21 1/2"
30"	22 1/2"
32"	23 1/2"
34"	24 1/2"
36"	25 1/2"
38"	26 1/2"
40"	27 1/2"
42"	28 1/2"
44"	29 1/2"
46"	30 1/2"
48"	31 1/2"

SYSTEM COMPONENTS

CUSTOM DIMENSIONS ARE AVAILABLE TO SUIT YOUR NEEDS IN EVEN AND ODD SIZES.

90° LATERAL TEE

PART NO. 90LT

The 90° Lateral Tee is used to join horizontal and vertical sections with lower resistance, as well as to provide for the connection of drain or inspection fittings. Use either the drain tee cap or the end cap for the closure of the unused opening.

Includes two inner bands and two outer bands.

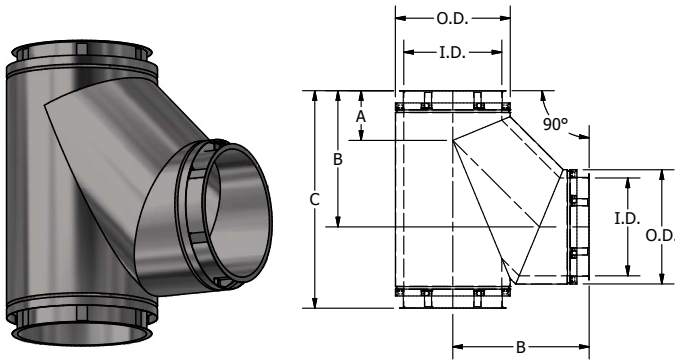

REDUCING 90° LATERAL TEE

PART NO. R90LT

The Reducing 90° Lateral Tee is used to join horizontal and vertical sections of different sizes with lower resistance, as well as to provide for the connection of drain or inspection fittings. Use either the drain tee cap or the end cap for the closure of the unused opening.

Includes one inner band and one outer band for larger and smaller openings.

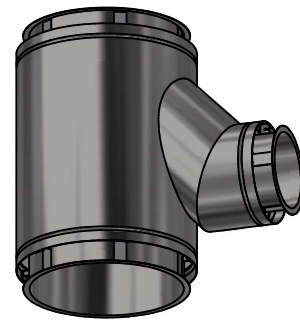

PART NO. 90LT			
I.D.	A	B	C
5"	4 5/8"	10 5/16"	16 3/4"
6"	4 7/8"	11 3/16"	18 3/16"
7"	5 1/16"	12 1/8"	19 5/8"
8"	5 1/4"	13 1/16"	21"
9"	5 7/16"	13 15/16"	22 7/16"
10"	5 11/16"	14 7/8"	23 7/8"
11"	5 7/8"	15 3/4"	25 1/4"
12"	6 1/16"	16 11/16"	26 11/16"
13"	6 5/16"	17 5/8"	28 1/16"
14"	6 1/2"	18 1/2"	29 1/2"
15"	6 11/16"	19 7/16"	30 15/16"
16"	6 15/16"	20 3/8"	32 5/16"
17"	7 1/8"	21 1/4"	33 3/4"
18"	7 5/16"	22 3/16"	35 3/16"
19"	7 9/16"	23 1/16"	36 9/16"
20"	7 3/4"	24"	38"
21"	7 15/16"	24 15/16"	39 3/8"
22"	8 3/16"	25 13/16"	40 13/16"
23"	8 3/8"	26 3/4"	42 1/4"
24"	8 9/16"	27 11/16"	43 5/8"

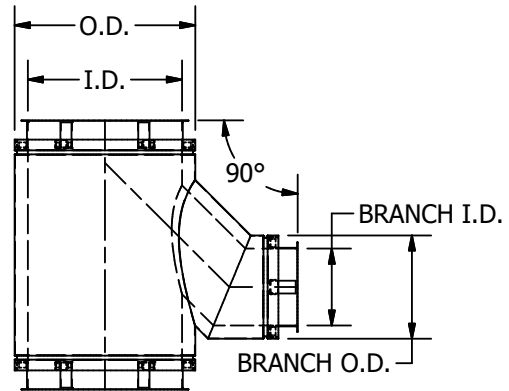

SYSTEM COMPONENTS

CUSTOM DIMENSIONS ARE AVAILABLE TO SUIT YOUR NEEDS IN EVEN AND ODD SIZES.

REDUCING 90° TEE

PART NO. R90T

The Reducing 90° Tee is used to join horizontal and vertical sections of different sizes, as well as provide for a connection to drain or inspect fittings. Use either the drain tee cap or the end cap for the closure of the unused opening. Specify the size of the branch required.

Includes one inner band and one outer band for larger and smaller openings.

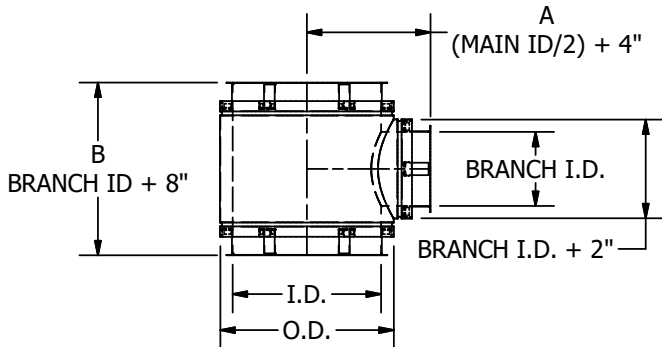
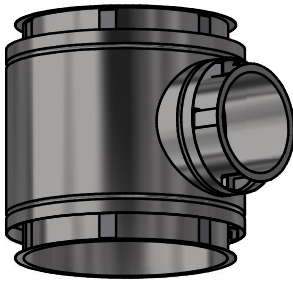

PART NO. R90T			
MAIN I.D.	A	BRANCH I.D.	B
6"	7"	5"	13"
7"	7 1/2"	6"	14"
8"	8"	7"	15"
9"	8 1/2"	8"	16"
10"	9"	9"	17"
11"	9 1/2"	10"	18"
12"	10"	11"	19"
13"	10 1/2"	12"	20"
14"	11"	13"	21"
15"	11 1/2"	14"	22"
16"	12"	15"	23"
17"	12 1/2"	16"	24"
18"	13"	17"	25"
19"	13 1/2"	18"	26"
20"	14"	19"	27"
21"	14 1/2"	20"	28"
22"	15"	21"	29"
23"	15 1/2"	22"	30"
24"	16"	23"	31"
25"	16 1/2"	24"	32"
26"	17"	25"	33"
27"	17 1/2"	26"	34"
28"	18"	27"	35"
29"	18 1/2"	28"	36"
30"	19"	29"	37"
31"	19 1/2"	30"	38"
32"	20"	31"	39"
33"	20 1/2"	32"	40"
34"	21"	33"	41"
35"	21 1/2"	34"	42"
36"	22"	35"	43"
37"	22 1/2"	36"	44"
38"	23"	37"	45"
39"	23 1/2"	38"	46"
40"	24"	39"	47"
41"	24 1/2"	40"	48"
42"	25"	41"	49"
43"	25 1/2"	42"	50"
44"	26"	43"	51"
45"	26 1/2"	44"	52"
46"	27"	45"	53"
47"	27 1/2"	46"	54"
48"	28"	47"	55"

SYSTEM COMPONENTS

CUSTOM DIMENSIONS ARE AVAILABLE TO SUIT YOUR NEEDS IN EVEN AND ODD SIZES.

ORIGINAL REDUCING 90° TEE

PART NO. OR90T

The Original Reducing 90° Tee is used to join horizontal and vertical sections of different sizes, as well as provide for a connection to drain or inspect fittings. Use either the drain tee cap or the end cap for closure of the unused opening. Specify the size of the branch required.

Includes one inner band and one outer band for larger and smaller openings.

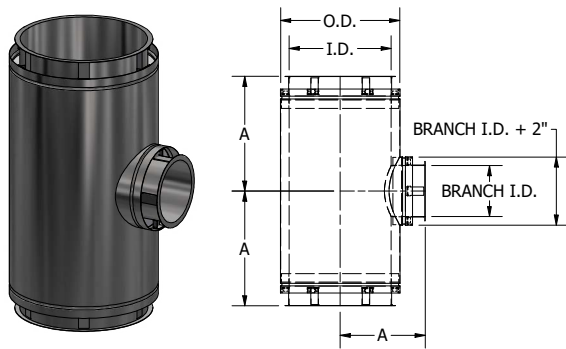

PART NO. OR90T	
I.D.	A
6"	10 1/2"
8"	11 1/2"
10"	12 1/2"
12"	13 1/2"
14"	14 1/2"
16"	15 1/2"
18"	16 1/2"
20"	17 1/2"
22"	18 1/2"
24"	19 1/2"
26"	20 1/2"
28"	21 1/2"
30"	22 1/2"
32"	23 1/2"
34"	24 1/2"
36"	25 1/2"
38"	26 1/2"
40"	27 1/2"
42"	28 1/2"
44"	29 1/2"
46"	30 1/2"
48"	31 1/2"

90° WYE

PART NO. 90Y

The 90° Wye is used for joining runs where low flow resistance is desired. All openings must be the same size. For connection to smaller diameter sections, use the tapered or abrupt increasers.

Includes two inner bands and two outer bands.

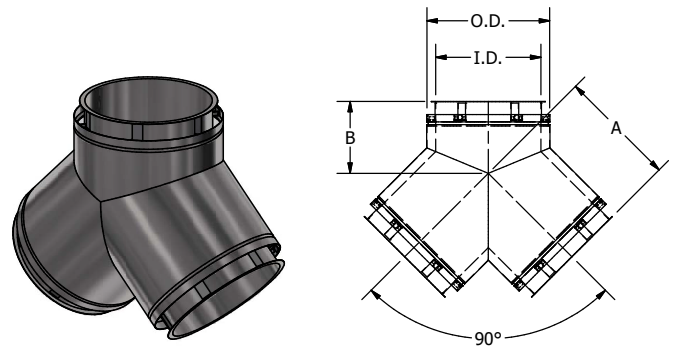

PART NO. 90Y		
I.D.	A	B
5"-6"	10 1/2"	7"
7"-8"	11 1/2"	7 13/32"
9"-10"	12 1/2"	7 13/16"
11"-12"	13 1/2"	8 7/32"
13"-14"	14 1/2"	8 5/8"
15"-16"	15 1/2"	9 1/16"
17"-18"	16 1/2"	9 7/16"
19"-20"	17 1/2"	9 7/8"
21"-22"	18 1/2"	10 9/32"
23"-24"	19 1/2"	10 23/32"
25"-26"	20 1/2"	11 1/8"
27"-28"	21 1/2"	11 17/32"
29"-30"	22 1/2"	11 31/32"
31"-32"	23 1/2"	12 3/8"
33"-34"	24 1/2"	12 25/32"
35"-36"	25 1/2"	13 3/16"
37"-38"	26 1/2"	13 11/16"
39"-40"	27 1/2"	14 1/32"
41"-42"	28 1/2"	14 15/32"
43"-44"	29 1/2"	14 27/32"
45"-46"	30 1/2"	15 1/4"
47"-48"	31 1/2"	15 11/16"

SYSTEM COMPONENTS

CUSTOM DIMENSIONS ARE AVAILABLE TO SUIT YOUR NEEDS IN EVEN AND ODD SIZES.

90° ELBOW PART NO. 90L

The 90° Elbow is used when making a 90° directional change. The 90° elbow is available in sizes 5" to 24". For a 90° directional change in diameters from 25" to 48", use two 45° elbows.

Includes one inner band and one outer band.

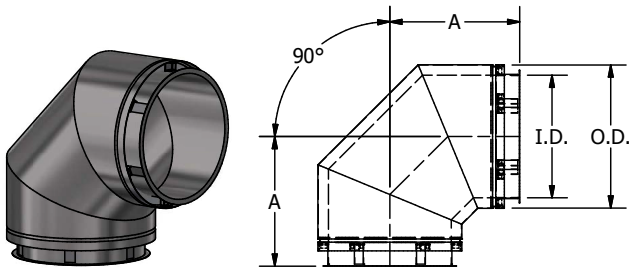

PART NO. 90L	
I.D.	A
6"	9 11/16"
8"	10 7/8"
10"	11 7/16"
12"	12 11/16"
14"	13 7/8"
16"	15 1/16"
18"	15 11/16"
20"	16 7/8"
22"	17 1/2"
24"	18 11/16"

ORIGINAL 90° ELBOW PART NO. 090L

The Original 90° Elbow is used when making a 90° directional change. The 90° elbow is available in sizes 5" to 24". For a 90° directional change in diameters from 25" to 48", use two 45° elbows.

Includes one inner band and one outer band.

Note: The Original 90° Elbow is a long sweep/large radius elbow compared to the 90° Elbow.

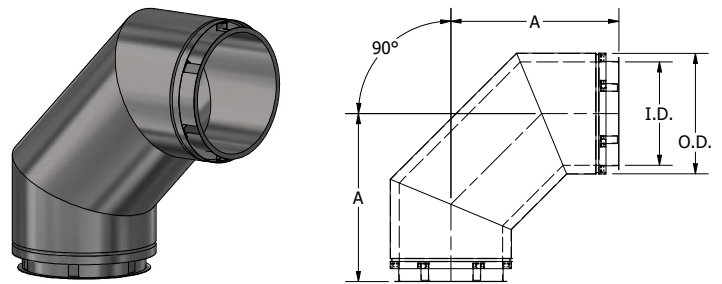

PART NO. 090L	
I.D.	A
6"	13 1/2"
8"	15 1/2"
10"	17 1/2"
12"	19 1/2"
14"	21 1/2"
16"	23 1/2"
18"	25 1/2"
20"	27 1/2"
22"	29 1/2"
24"	31 1/2"

SYSTEM COMPONENTS

CUSTOM DIMENSIONS ARE AVAILABLE TO SUIT YOUR NEEDS IN EVEN AND ODD SIZES.

45° ELBOW PART NO. 45L

The 45° Elbow is used when a vertical or horizontal direction change of 45° is desired.

Includes one inner band and one outer band.

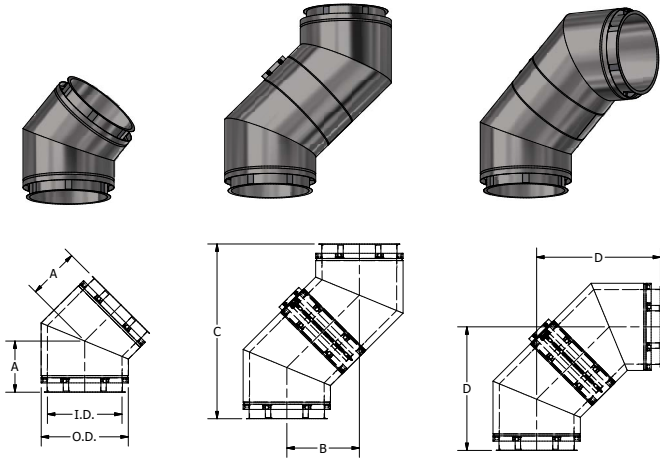

PART NO. 45L				
I.D.	A	B	C	D
5"-6"	7"	9 29/32"	23 29/32"	16 29/32"
7"-8"	7 3/8"	10 7/16"	25 3/16"	17 13/16"
9"-10"	7 13/16"	11 3/64"	26 43/64"	18 55/64"
11"-12"	8 1/4"	11 43/64"	28 11/64"	19 59/64"
13"-14"	8 5/8"	12 13/64"	29 29/64"	20 53/64"
15"-16"	9 1/16"	12 13/16"	30 15/16"	21 7/8"
17"-18"	9 1/2"	13 7/16"	32 7/16"	22 15/16"
19"-20"	9 7/8"	13 31/32"	33 23/32"	23 27/32"
21"-22"	10 5/16"	14 37/64"	35 13/64"	24 57/64"
23"-24"	10 3/4"	15 13/64"	36 45/64"	25 61/64"
25"-26"	11 1/8"	15 47/64"	37 63/64"	26 55/64"
27"-28"	11 9/16"	16 23/64"	39 31/64"	27 59/64"
29"-30"	11 15/16"	16 7/8"	40 3/4"	28 13/16"
31"-32"	12 3/8"	17 1/2"	42 1/4"	29 7/8"
33"-34"	12 3/4"	18 1/32"	43 17/32"	30 25/32"
35"-36"	13 3/16"	18 21/32"	45 1/32"	31 27/32"
37"-38"	13 5/8"	19 17/64"	46 33/64"	32 57/64"
39"-40"	14"	19 51/64"	47 51/64"	33 51/64"
41"-42"	14 7/16"	20 27/64"	49 19/64"	34 55/64"
43"-44"	14 7/8"	21 1/32"	50 25/32"	35 29/64"
45"-46"	15 1/4"	21 9/16"	52 1/16"	36 13/16"
47"-48"	15 11/16"	22 3/16"	53 9/16"	37 7/8"

30° ELBOW PART NO. 30L

The 30° Elbow is used when a vertical or horizontal direction change of 30° is desired.

Includes one inner band and one outer band.

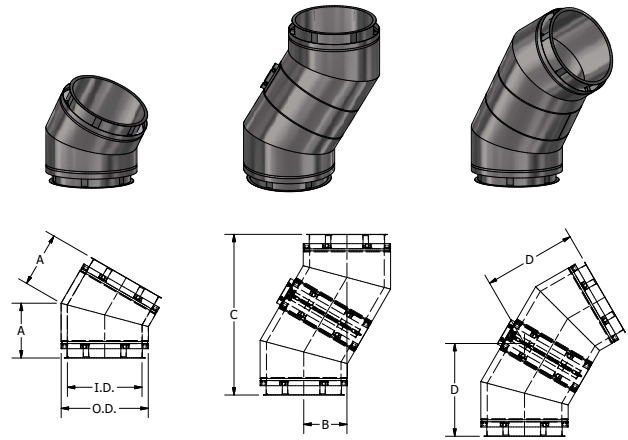

PART NO. 30L				
I.D.	A	B	C	D
5"-6"	6 1/8"	6 1/8"	22 55/64"	13 13/64"
7"-8"	6 3/8"	6 3/8"	23 51/64"	13 47/64"
9"-10"	6 5/8"	6 5/8"	24 23/32"	14 9/32"
11"-12"	6 15/16"	6 15/16"	25 57/64"	14 61/64"
13"-14"	7 3/16"	7 3/16"	26 53/64"	15 31/64"
15"-16"	7 7/16"	7 7/16"	27 3/4"	16 1/32"
17"-18"	7 3/4"	7 3/4"	28 59/64"	16 45/64"
19"-20"	8"	8"	29 55/64"	17 15/64"
21"-22"	8 1/4"	8 1/4"	30 51/64"	17 23/32"
23"-24"	8 1/2"	8 1/2"	31 23/32"	18 5/16"
25"-26"	8 3/4"	8 3/4"	32 21/32"	18 55/64"
27"-28"	9 1/16"	9 1/16"	33 53/64"	19 17/32"
29"-30"	9 5/16"	9 5/16"	34 3/4"	20 1/16"
31"-32"	9 9/16"	9 9/16"	35 11/16"	20 39/64"
33"-34"	9 7/8"	9 7/8"	36 55/64"	21 9/32"
35"-36"	10 1/8"	10 1/8"	37 25/32"	21 13/16"
37"-38"	10 3/8"	10 3/8"	38 23/32"	22 23/64"
39"-40"	10 5/8"	10 5/8"	39 21/32"	22 57/64"
41"-42"	10 15/16"	10 15/16"	40 13/16"	23 9/16"
43"-44"	11 3/16"	11 3/16"	41 3/4"	24 7/64"
45"-46"	11 1/2"	11 1/2"	42 59/64"	24 25/32"
47"-48"	11 3/4"	11 3/4"	43 55/64"	25 5/16"

SYSTEM COMPONENTS

CUSTOM DIMENSIONS ARE AVAILABLE TO SUIT YOUR NEEDS IN EVEN AND ODD SIZES.

END CAP

PART NO. EC

The End Cap is used to close an unused tee opening and to provide a means of accessing the interior of the system for inspection and cleaning.

Includes one inner band.

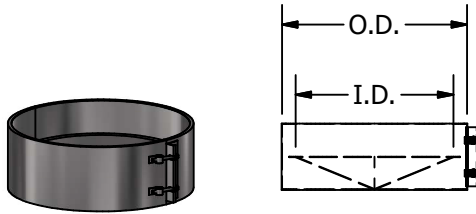

PART NO. EC	
I.D.	O.D.
6"	8"
8"	10"
10"	12"
12"	14"
14"	16"
16"	18"
18"	20"
20"	22"
22"	24"
24"	26"
26"	28"
28"	30"
30"	32"
32"	34"
34"	36"
36"	38"
38"	40"
40"	42"
42"	44"
44"	46"
46"	48"
48"	50"

DRAIN TEE CAP

PART NO. DTC

The Drain Tee Cap is used to close an unused tee opening and to provide a drain at the base of a vertical chimney.

Includes one inner band.

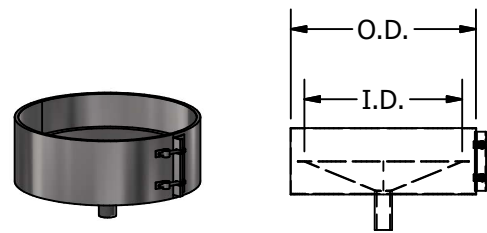

PART NO. DTC	
I.D.	O.D.
6"	8"
8"	10"
10"	12"
12"	14"
14"	16"
16"	18"
18"	20"
20"	22"
22"	24"
24"	26"
26"	28"
28"	30"
30"	32"
32"	34"
34"	36"
36"	38"
38"	40"
40"	42"
42"	44"
44"	46"
46"	48"
48"	50"

SYSTEM COMPONENTS

CUSTOM DIMENSIONS ARE AVAILABLE TO SUIT YOUR NEEDS IN EVEN AND ODD SIZES.

DRAIN SECTION

PART NO. DS

The Drain Section is used to drain rainwater and condensation from within the stack. The NPT nipple should be connected to a suitable drain.

Includes one inner band and one outer band.

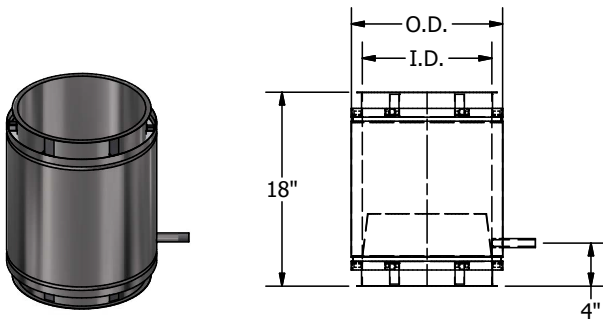

PART NO. DS	
I.D.	O.D.
6"	8"
8"	10"
10"	12"
12"	14"
14"	16"
16"	18"
18"	20"
20"	22"
22"	24"
24"	26"
26"	28"
28"	30"
30"	32"
32"	34"
34"	36"
36"	38"
38"	40"
40"	42"
42"	44"
44"	46"
46"	48"
48"	50"

HORIZONTAL DRAIN

PART NO. HD

The Horizontal Drain is used to drain rainwater and condensation from within the stack. The NPT nipple should be connected to a suitable drain.

Includes one inner band and one outer band.

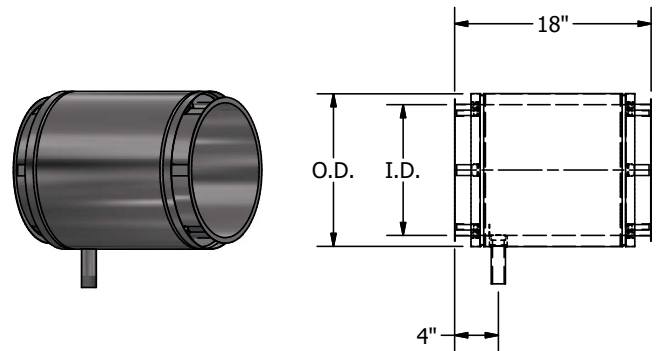

PART NO. HD	
I.D.	O.D.
6"	8"
8"	10"
10"	12"
12"	14"
14"	16"
16"	18"
18"	20"
20"	22"
22"	24"
24"	26"
26"	28"
28"	30"
30"	32"
32"	34"
34"	36"
36"	38"
38"	40"
40"	42"
42"	44"
44"	46"
46"	48"
48"	50"

SYSTEM COMPONENTS

CUSTOM DIMENSIONS ARE AVAILABLE TO SUIT YOUR NEEDS IN EVEN AND ODD SIZES.

BASE DRAIN SECTION

PART NO. BD

The Base Drain Section provides a bottom closure and a drain attachment for base-supported chimneys.

Includes one inner band and one outer band.

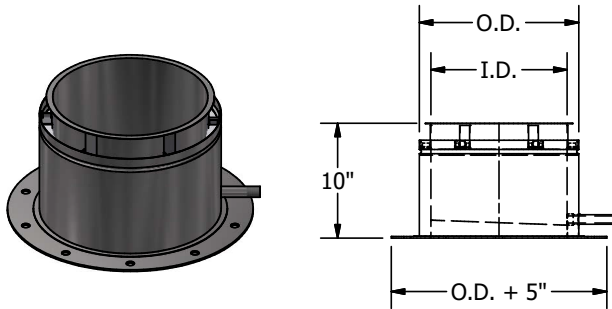

PART NO. BD	
I.D.	O.D.
6"	8"
8"	10"
10"	12"
12"	14"
14"	16"
16"	18"
18"	20"
20"	22"
22"	24"
24"	26"
26"	28"
28"	30"
30"	32"
32"	34"
34"	36"
36"	38"
38"	40"
40"	42"
42"	44"
44"	46"
46"	48"
48"	50"

FLASHING

PART NO. FL

The Flashing is used in conjunction with the rain collar to seal roof penetrations. This part is designed for flat roofs. Custom-pitched flashings are available upon request.

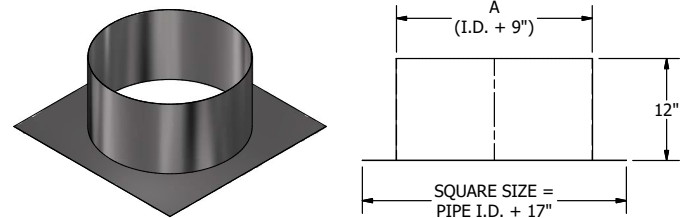

RAIN COLLAR

PART NO. RC

The Rain Collar is used in conjunction with the flashing to seal roof penetrations.

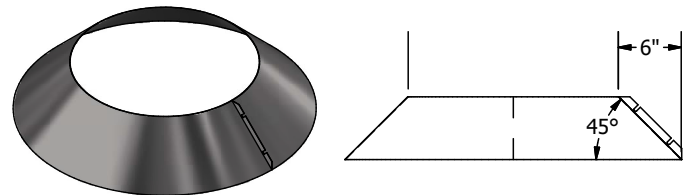

INSULATED THIMBLE

PART NO. IT

The Insulated Thimble is used when penetrating a combustible wall or roof. This part is designed for flat roofs. Custom-pitched thimbles are available upon request.

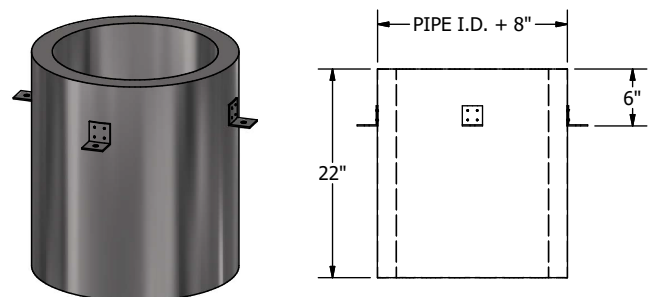

SYSTEM COMPONENTS

CUSTOM DIMENSIONS ARE AVAILABLE TO SUIT YOUR NEEDS IN EVEN AND ODD SIZES.

RAIN CAP PART NO. CC

The Rain Cap is used at stack terminations to prevent rainwater from entering the flue. A drain should be used at the base of stacks to drain off water that may be blown into the flue.

Includes one inner band and one closure ring to seal the outer shell joint.

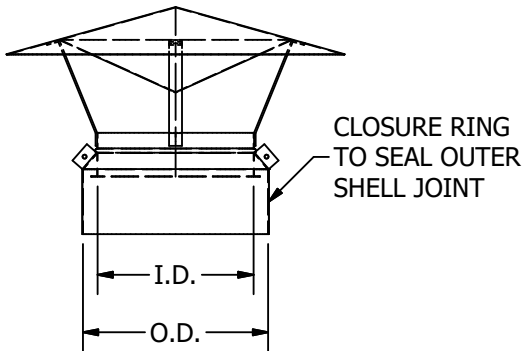
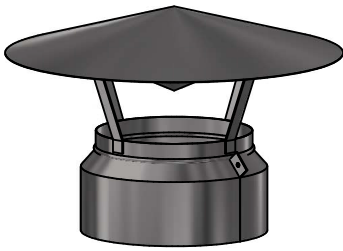

FAN ADAPTER PART NO. FA

The Fan Adapter is used to attach a grease duct to an exhaust fan or kitchen hood.

Includes one inner band and one outer band.

Note: Plenum boxes are available for multiple-fan systems.

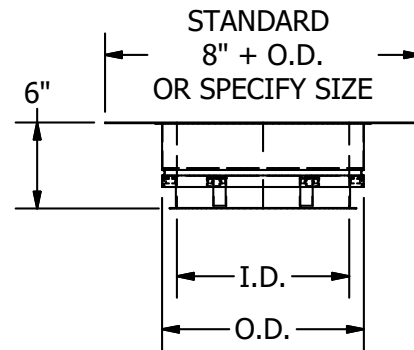
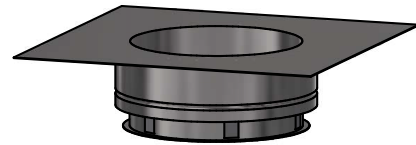

SYSTEM COMPONENTS

CUSTOM DIMENSIONS ARE AVAILABLE TO SUIT YOUR NEEDS IN EVEN AND ODD SIZES.

TOP SECTION

PART NO. TS

The Top Section is used to protect the insulating space between the inner and outer shells when an open termination is required. A drain should be used at the base of the stacks to drain off water that enters the system.

Includes one inner band and one closure ring to seal the outer shell joint.

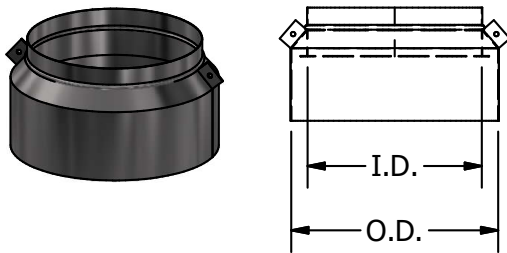

PART NO. TS	
I.D.	A
6"	8"
8"	10"
10"	12"
12"	14"
14"	16"
16"	18"
18"	20"
20"	22"
22"	24"
24"	26"
26"	28"
28"	30"
30"	32"
32"	34"
34"	36"
36"	38"
38"	40"
40"	42"
42"	44"
44"	46"
46"	48"
48"	50"

FLIP TOP CAP

PART NO. FTC

The Flip Top Cap is used in generator systems when the cap remains closed until pressure opens the cap.

Includes one inner band and one closure ring to seal the outer shell joint.

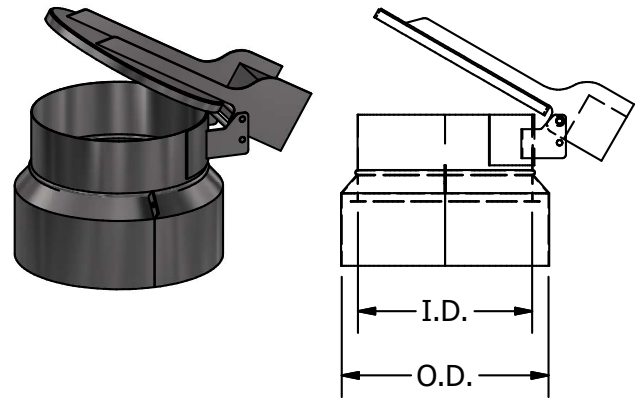

PART NO. FTC	
I.D.	A
6"	8"
8"	10"
10"	12"
12"	14"
14"	16"
16"	18"
18"	20"
20"	22"
22"	24"
24"	26"
26"	28"
28"	30"
30"	32"
32"	34"
34"	36"
36"	38"
38"	40"
40"	42"
42"	44"
44"	46"
46"	48"
48"	50"

SYSTEM COMPONENTS

CUSTOM DIMENSIONS ARE AVAILABLE TO SUIT YOUR NEEDS IN EVEN AND ODD SIZES.

EXIT CONE PART NO. EXC

The Exit Cone is used to increase the flue gas velocity exiting the stack. A drain should be used at the base of the stacks to remove any water that enters the stack.

Includes one inner band and one closure ring to seal the outer shell joint.

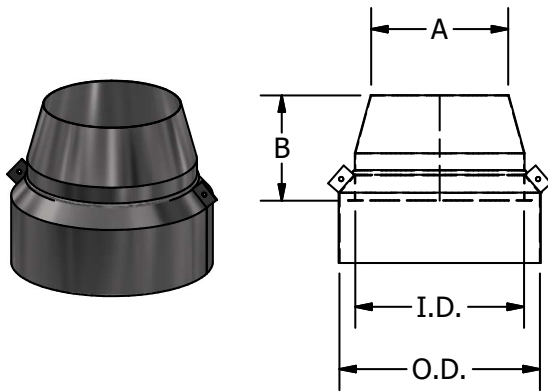

PART NO. EXC		
I.D.	A	B
6"	4 7/8"	5 3/8"
8"	6 1/2"	6 1/8"
10"	8 1/8"	6 3/4"
12"	9 3/4"	7 1/2"
14"	11 3/8"	8 1/8"
16"	13 1/8"	8 7/8"
18"	14 3/4"	9 1/2"
20"	16 3/8"	10 1/4"
22"	18"	10 7/8"
24"	19 5/8"	11 5/8"
26"	21 1/4"	12 1/4"
28"	22 7/8"	13"
30"	24 1/2"	13 5/8"
32"	26 1/8"	14 3/8"
34"	27 3/4"	15"
36"	29 3/8"	15 3/4"
38"	31"	16 3/8"
40"	32 5/8"	17 1/8"
42"	34 1/4"	17 3/4"
44"	35 7/8"	18 1/2"
46"	37 1/2"	19 1/8"
48"	39 1/4"	19 3/4"

HORIZONTAL TERMINATION PART NO. HT

The Horizontal Termination is used when the stack terminates in a horizontal position. Bird screen covers the opening to prevent any birds or rodents from entering.

Includes one inner and one outer band.

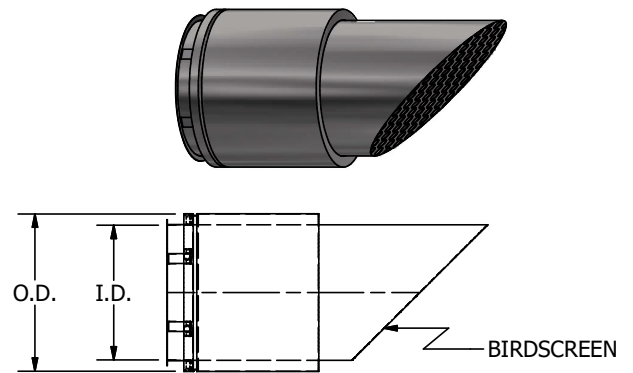

PART NO. HT	
I.D.	A
6"	8"
8"	10"
10"	12"
12"	14"
14"	16"
16"	18"
18"	20"
20"	22"
22"	24"
24"	26"
26"	28"
28"	30"
30"	32"
32"	34"
34"	36"
36"	38"
38"	40"
40"	42"
42"	44"
44"	46"
46"	48"
48"	50"

SYSTEM COMPONENTS

CUSTOM DIMENSIONS ARE AVAILABLE TO SUIT YOUR NEEDS IN EVEN AND ODD SIZES.

GUY SECTION

PART NO. GS

The Guy Section is to be used when the chimney extends beyond the vertical limits above the roof line. The guy section should be connected to guy wires or a rigid guying structure.

Includes two half-outer bands.

Note: This part must be placed at the connection of two flue sections.

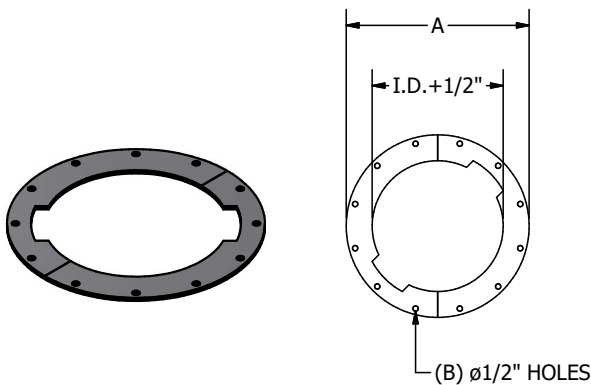

PART NO. GS		
I.D.	A	B
6"	10 5/8"	8
8"	12 5/8"	8
10"	15 3/16"	12
12"	17 3/16"	12
14"	19 3/16"	12
16"	21 3/16"	12
18"	23 3/16"	12
20"	25 3/16"	12
22"	27 3/16"	12
24"	30 3/16"	12
26"	32 3/16"	12
28"	34 3/16"	16
30"	36 3/16"	16
32"	38 3/16"	16
34"	40 3/16"	16
36"	42 3/16"	20
38"	44 3/16"	20
40"	46 3/16"	20
42"	48 3/16"	20
44"	50 3/16"	24
46"	52 3/16"	24
48"	54 3/16"	28

SUPPORT PLATE

PART NO. SP

The Support Plate is the primary load-carrying member of the chimney assembly. This part is designed to support (B) (see chart below) feet of vertical chimney section as well as provide fixed points in breaching runs.

Includes two half-outer bands.

Note: This part must be placed at the connection of two flue sections.

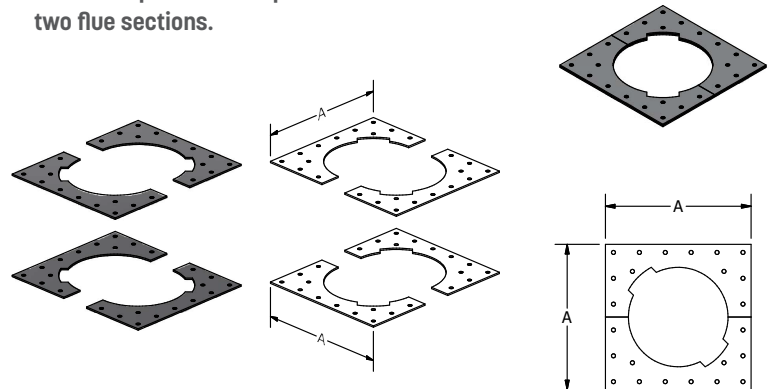

PART NO. SP		
I.D.	A	B (FT)
6"	12"	403'
8"	14"	389'
10"	16"	375'
12"	18"	361'
14"	20"	347'
16"	22"	334'
18"	24"	320'
20"	26"	306'
22"	28"	292'
24"	30"	278'
26"	32"	264'
28"	34"	250'
30"	36"	236'
32"	38"	222'
34"	40"	208'
36"	42"	195'
38"	44"	181'
40"	46"	167'
42"	48"	153'
44"	50"	139'
46"	52"	125'
48"	54"	111'

SYSTEM COMPONENTS

CUSTOM DIMENSIONS ARE AVAILABLE TO SUIT YOUR NEEDS IN EVEN AND ODD SIZES.

WALL SUPPORT

PART NO. WS

The Wall Support is used to provide chimney support along a wall. The wall support will maintain the required clearance to combustible structures when properly installed and can support (C) (see chart below) feet of vertical chimney.

Includes two half-outer bands.

Note: This part must be placed at the connection of two flue sections.

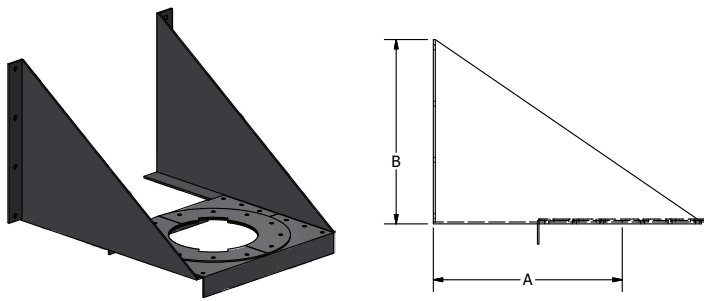

PART NO. WS			
I.D.	A	B	C (FT)
6"	11"	12 3/8"	17'
8"	13"	14 3/8"	156'
10"	14"	15 3/4"	147'
12"	15"	17 1/16"	138'
14"	17"	19 1/8"	132'
16"	18"	20 7/16"	127'
18"	20"	22 1/2"	120'
20"	21"	24 1/8"	116'
22"	23"	26 3/16"	111'
24"	24"	27 1/2"	107'
26"	26"	29 1/2"	103'
28"	27"	30 7/8"	97'
30"	29"	32 7/8"	93'
32"	30"	34 1/4"	108'
34"	32"	36 1/4"	102'
36"	33"	37 5/8"	80'
38"	35"	39 9/16"	75'
40"	36"	40 15/16"	71'
42"	38"	42 15/16"	67'
44"	39"	44 5/16"	63'
46"	44"	47"	59'
48"	45"	49 11/16"	56'

FLOOR/ROOF GUIDE

PART NO. FRG

The Floor/Roof Guide is used at the penetration of floors and roofs to guide the chimney. This part is designed to absorb lateral loads only. It will not support vertical chimney sections.

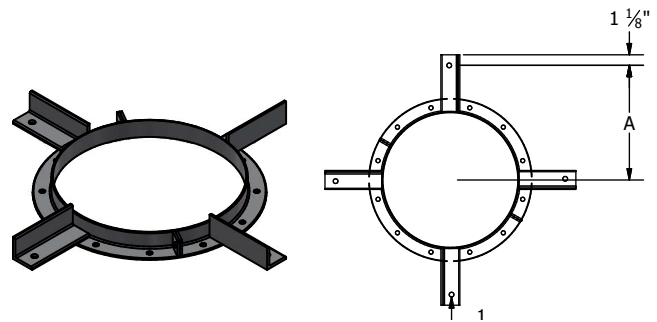

PART NO. FRG	
I.D.	A
6"	9 1/8"
8"	10 1/8"
10"	11 1/8"
12"	12 1/8"
14"	13 3/16"
16"	14 3/16"
18"	15 3/16"
20"	16 3/16"
22"	17 3/16"
24"	18 3/16"
26"	19 3/16"
28"	20 3/16"
30"	21 3/16"
32"	22 3/16"
34"	23 3/16"
36"	24 3/16"
38"	25 3/16"
40"	26 3/16"
42"	27 3/16"
44"	28 3/16"
46"	29 3/16"
48"	30 3/16"

SYSTEM COMPONENTS

CUSTOM DIMENSIONS ARE AVAILABLE TO SUIT YOUR NEEDS IN EVEN AND ODD SIZES.

WALL GUIDE

PART NO. WG

The Wall Guide is used to guide long vertical runs placed adjacent to walls. This part will maintain proper clearance to combustibles when properly installed.

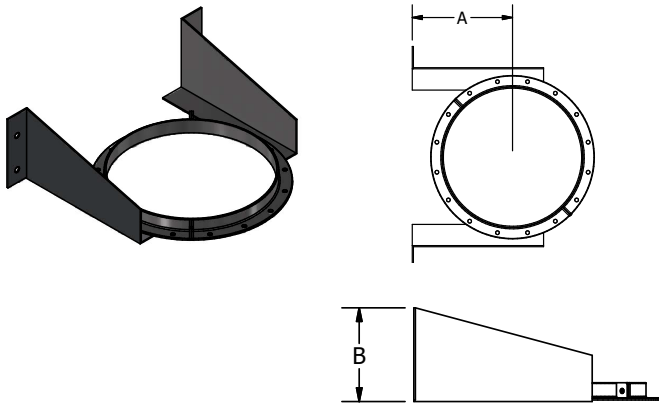

PART NO. WG		
I.D.	A	B
5"-6"	11"	7 13/16"
7"-8"	13"	8 1/2"
9"-10"	14"	8 5/8"
11"-12"	15"	9"
13"-14"	17"	9 7/16"
15"-16"	18"	9 3/4"
17"-18"	20"	10 1/4"
19"-20"	21"	10 9/16"
21"-22"	23"	11 1/8"
23"-24"	24"	11 5/16"
25"-26"	26"	11 7/8"
27"-28"	27"	12 1/8"
29"-30"	29"	12 11/16"
31"-32"	30"	12 15/16"
33"-34"	32"	13 1/2"
35"-36"	33"	13 11/16"
37"-38"	35"	14 5/16"
39"-40"	36"	14 1/2"
41"-42"	38"	15 1/16"
43"-44"	39"	15 5/16"
45"-46"	44"	16 11/16"
47"-48"	45"	16 7/8"

FULL RING

PART NO. FR

The Full Ring is used to guide horizontal and vertical runs. The part is simply bolted around the outer shell, then rigidly connected to the building structure.

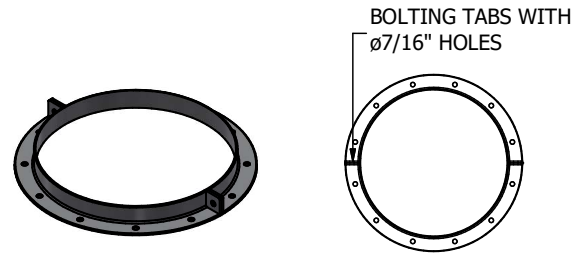

HANGER

PART NO. HG

The Hanger is used to support long horizontal runs, placed under the flue and then supported by rods connecting to the building structure.

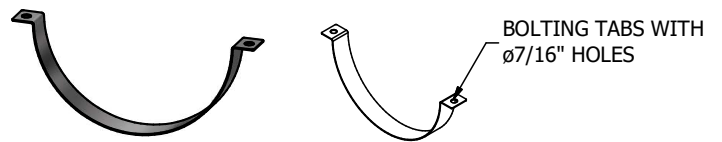

PRESSURE RELIEF VALVE

PART NO. PRV

The Pressure Relief Valve is used in generator exhaust systems to prevent damage resulting in the ignition of unburned fuel. This component complies with NFPA 37.

Valves are set to 1 PSI.

Includes one inner band and one seal ring to cover the gap between the inner and outer shells.

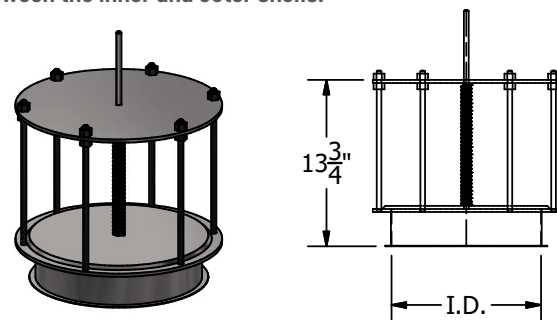

SYSTEM COMPONENTS

CUSTOM DIMENSIONS ARE AVAILABLE TO SUIT YOUR NEEDS IN EVEN AND ODD SIZES.

SQUARE-TO-ROUND TRANSITIONS

The Square-to-Round Transitions are used when connecting to appliances with square or rectangular outlets. The base can be raw for field welding or flanged for field drilling and bolting.

Note: This part will be custom-built/coordinated with the design team for each application.

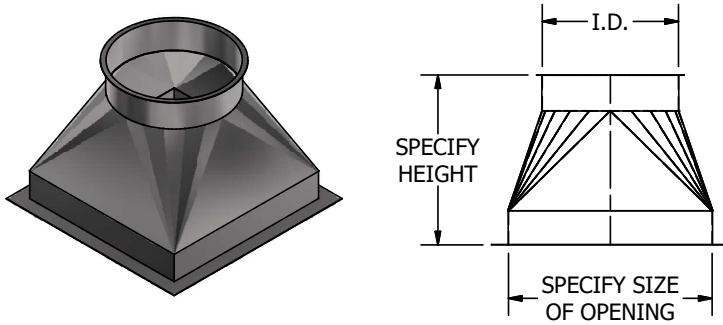

OUTER SHELL TEMP CHART

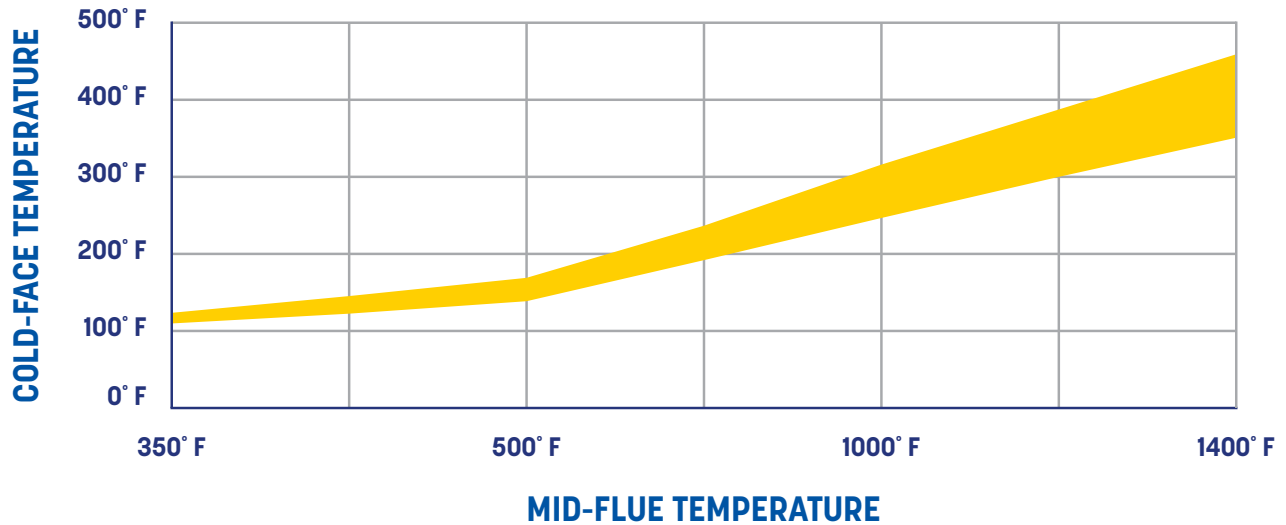

SYSTEM SPECS AND COMPONENTS

CUSTOM DIMENSIONS ARE AVAILABLE TO SUIT YOUR NEEDS IN EVEN AND ODD SIZES.

P1 WEIGHT CHART

Part Description	Part No.	INSIDE DIAMETER (INCHES)																					
		6"	8"	10"	12"	14"	16"	18"	20"	22"	24"	26"	28"	30"	32"	34"	36"	38"	40"	42"	44"	46"	48"
14" to 17" Adjustable	18AL	13 lbs.	16	20	23	26	30	33	36	40	43	46	50	53	56	60	75	92	97	101	106	111	118
16" to 21" Adjustable	22AL	15 lbs.	19	23	27	31	34	38	42	46	50	54	58	62	66	69	88	107	113	118	124	129	135
20" to 29" Adjustable	30AL	19 lbs.	24	29	34	39	44	49	54	59	64	69	74	79	84	89	113	138	145	152	159	166	173
27 1/2" to 44" Adjustable	45AL	26 lbs.	33	40	48	55	62	69	76	83	90	97	105	112	119	126	162	195	205	215	225	235	245
29" Straight Section	29S	17 lbs.	22	27	31	36	40	45	49	54	59	63	68	73	77	82	104	126	133	139	146	152	159
30 Degree Elbow	30L	9 lbs.	11	14	16	19	22	26	29	38	42	47	52	57	62	67	72	91	98	105	112	120	127
45 Degree Elbow	45L	19 lbs.	12	15	19	22	26	30	34	46	52	58	64	71	78	85	92	116	125	135	145	154	165
45 Degree Lateral Tee	45LT	23 lbs.	32	41	52	63	76	90	105	146	167	189	213	238	263	290	319	400	435	472	511	551	593
47" Straight Section	47S	26 lbs.	33	40	48	55	62	69	76	83	90	97	105	112	119	126	162	195	205	215	225	235	245
59" Straight Section	59S	-	40	49	59	67	76	85	94	103	111	-	-	-	-	-	-	-	-	-	-	-	-
90 Degree Elbow	90L	14 lbs.	19	26	33	42	51	61	72	103	119	-	-	-	-	-	-	-	-	-	-	-	-
90 Degree Tee	90T	19 lbs.	25	31	39	46	55	63	73	99	112	125	139	154	169	186	202	254	275	297	319	342	366
90 Degree Wye	90Y	17 lbs.	22	28	34	41	48	56	64	87	98	109	121	134	148	162	176	222	240	259	278	298	319
Abrupt Increaser	AI	7 lbs.	8	10	12	13	15	17	18	20	22	23	25	27	28	30	32	40	42	44	46	48	52
Base Drain	BD	13 lbs.	15	18	21	24	27	30	33	36	39	42	45	48	51	54	63	76	80	83	87	91	95
Bellows Section	BS	14 lbs.	18	21	25	28	32	36	39	43	46	50	54	57	61	65	81	100	105	110	115	120	125
Boiler Kit Flanged	BKF	7 lbs.	8	10	12	13	15	17	18	20	22	23	25	27	28	30	32	40	42	44	46	48	52
Boiler Kit Raw	BKR	4 lbs.	5	6	7	8	8	9	10	11	12	13	14	15	15	16	17	25	26	27	29	30	31
Drain Section	DS	12 lbs.	16	19	22	25	28	32	35	38	41	44	48	51	54	57	72	88	93	97	102	106	111
Drain Tee Cap	DTC	5 lbs.	6	7	8	9	11	12	14	16	18	20	22	25	27	30	42	51	55	59	64	69	74
End Cap	EC	4 lbs.	5	6	7	8	10	11	13	15	17	19	21	24	26	29	41	50	54	58	63	68	73
Fan Adapter	FA	11 lbs.	13	16	18	21	23	26	28	31	34	36	39	42	44	47	55	67	70	74	77	81	85
Flashing	FL	11 lbs.	12	13	15	16	18	19	21	22	24	25	27	29	30	32	34	35	37	39	40	42	44
Floor/Roof Guide	FRG	10 lbs.	10	11	12	15	16	17	18	19	24	25	27	27	30	30	32	33	34	35	36	38	39
Full Ring	FR	3 lbs.	4	5	6	9	10	11	12	13	18	19	21	21	24	24	26	27	28	29	30	32	33
Guy Section	GS	9 lbs.	11	13	14	16	18	20	22	23	25	27	29	31	32	34	36	42	44	46	48	50	52
Hanger	HG	2 lbs.	2	3	3	5	5	5	6	6	9	10	10	11	12	12	13	13	14	15	15	16	17
Horizontal Drain	HD	12 lbs.	16	19	22	25	28	32	35	38	41	44	48	51	54	57	72	88	93	97	102	106	111
Insulated Thimble	IT	20 lbs.	22	25	28	31	33	36	39	42	44	47	50	52	55	58	61	63	66	69	72	74	77
Nozzle Section	NS	12 lbs.	16	19	22	25	28	32	35	38	41	44	48	51	54	57	72	88	93	97	102	106	111
Rain Cap	CC	9 lbs.	11	13	16	18	21	24	27	31	34	37	41	45	52	57	65	73	79	86	92	99	105
Rain Collar	RC	4 lbs.	4	5	5	6	6	7	7	8	8	9	9	10	10	11	11	12	12	13	13	14	14
Support Plate	SP	31 lbs.	36	42	47	53	58	64	70	76	99	107	114	122	130	138	146	186	196	206	217	227	238
Tapered Increaser	TI	14 lbs.	18	22	26	29	33	37	41	53	58	62	66	71	76	80	84	104	109	114	119	125	130
Top Section	TS	3 lbs.	4	5	5	6	7	8	9	9	10	11	12	12	13	14	17	21	22	23	24	25	26
Variable Section	VS	26 lbs.	33	32	48	55	62	69	76	83	90	97	105	112	119	126	162	195	205	215	225	235	245
Wall Guide	WG	14 lbs.	17	17	21	26	28	31	34	37	44	48	50	53	57	60	62	66	69	73	75	85	87
Wall Support	WS	53 lbs.	65	65	86	101	113	129	144	162	192	212	229	252	270	294	313	364	386	415	438	476	515

All weights shown above are actual weights; for shipping weights, multiply by 1.25



SAMPLE SPECIFICATION

MODEL P1

The factory-built modular chimney shall be laboratory tested and listed in accordance with Underwriters Laboratories Standard UL 103, Standard for factory-built chimneys for building heating appliances, UL 2561, Standard for 1,400°F factory-built chimneys for use with building heating equipment burning gas, solid or liquid fuels with flue gases not exceeding 1,400°F continuous operations and 1,800°F intermittent operation and UL 103HT suitable for exposures to 2,100°F for a ten minute duration. It shall also be tested and listed for use as a grease duct in accordance with UL 1978. Sections shall bear the UL listing mark and cUL listing mark for Canada. Sections shall be sealed with banded flanges and joint sealant specific to the application.

Inner shell material shall be type 304 stainless steel for natural gas and number 2 oil-fired appliances, type 316 stainless steel for coal, number 4 and number 6 oil-fired appliances. Inner shell thickness shall be 0.036" for 5" to 36" diameter systems and 0.048" for 38" to 48" diameter systems. All inner shell seams shall be full penetration welded the entire length of the pipe section. Riveted, tack or spot-welded seams are not permitted.

Outer shell material shall be 430 stainless steel with a thickness of 0.028" for 5" to 36" diameter systems and 0.048" for 37" to 48" diameter systems. All outer shell seams shall be full penetration welded the entire length of the pipe section. Riveted, tack or spot-welded seams are not permitted.

Between the inner and outer shells there shall be a minimum 1" of 1,600°F-rated low-conductivity ceramic fiber insulation. The insulation is to be securely attached to the inner shell with steel straps and insulating pins welded to the inner shell. Stainless-steel centering clips shall be welded to the outer shell to maintain the 1" spacing and ensure concentricity of the shells.

Breeching and chimney sections, when installed according to manufacturer instructions, shall comply with national safety standards and building codes. Stacks terminating above a roof must terminate as required by code or NFPA 211.

SCHER

5-YEAR WARRANTY MODEL P1 STANDARD

The Schebler Model P1 Chimney, where installed according to the manufacturer's installation instructions, is warranted by the Schebler Company for a period of five (5) years from the date of system start-up against defects in material and workmanship of the product for parts only. Any defective part in the product will, at Schebler's option, either be repaired or replaced. Should the part be returned, the owner must pay all transportation charges. The repaired or replacement part will, in turn, be shipped by Schebler to the owner, freight prepaid. The warranty on any repaired or replacement part shall be for a duration of time no longer than the remaining or unexpired term of the original warranty.

This warranty does not cover labor or other service charges incurred by the owner, nor any parts not manufactured by the Schebler Company, or any other components that are not part of the Model P1 chimney systems.

This limited warranty is extended to the purchaser, subject to the satisfaction of the following conditions:

1. Generally accepted engineering practices have been followed to determine that sizing and material specifications are suitable for the application and environment involved.
2. The undamaged components have been correctly installed in accordance with the installation instructions published by the Schebler Company at the time of shipment.

The Schebler Company assumes no liability for incidental or consequential damages of any kind or for any damages resulting in whole or part from misuse, improper installation or inadequate maintenance of the system or component part thereof. This warranty is in lieu of all other express warranties or guarantees of any kind. All implied warranties, including merchantability and fitness, are limited to the duration of the express warranty contained herein. The Schebler Company neither assumes nor does it authorize any other person to assume on its behalf any other liability in connection with the sale of its products.

10-YEAR WARRANTY MODEL P1 EXTENDED

The Schebler Company warrants owners of its Model P1 Chimney against defects in material and workmanship in normal use for ten (10) years from the date of delivery to the construction site when installed, maintained and used as part of a Schebler Model P1 chimney system and in accordance with the Schebler Company specifications. The Schebler Company further warrants any portion of the chimney system repaired or replaced under this warranty for the remainder of the original warranty period.

This warranty is limited to the repair or replacement of the product, plus shipping costs, to the failure location. This warranty does not cover any labor costs for removal or replacement of the defective product, nor does this warranty cover any system components not furnished by the Schebler Company and installed as part of the system.

This limited warranty is extended to the purchaser, subject to the satisfaction of the following conditions:

- 1.** System sizing and design has been performed by Schebler personnel and design parameters provided to the Schebler Company by the responsible engineer were and are accurately representative of the operating conditions.
- 2.** The undamaged components have been correctly installed in accordance with system design and sizing as performed by Schebler and installation instructions published by the Schebler Company at the time of shipment.
- 3.** Proper precautions have been taken to ensure that appliance air is free of solvent or refrigerant vapors or any halogenated compound which may cause acid condensate to form within the chimney.
- 4.** The Schebler Company has supplied the entire chimney or exhaust system from the appliance outlet to the termination of the stack.
- 5.** Prior to start-up and thereafter, exposed aluminized steel surfaces are protected with a minimum of one base coat of primer and one finish coat of heat-resistant paint at all times.

The Schebler Company assumes no liability for incidental or consequential damages of any kind or for any damages resulting in whole or in part from misuse, improper installation or inadequate maintenance of the system or component part thereof. This warranty is in lieu of all other express warranties or guarantees of any kind. All implied warranties, including merchantability and fitness, are limited to the duration of the express warranty contained herein. The Schebler Company neither assumes nor does it authorize any other person to assume on its behalf any other liability in connection with the sale of its products.

Model P1

PREFABRICATED STAINLESS STEEL VENT FROM SCHEBLER

The P Series is not only the industry's highest-quality general-purpose stainless steel vent, but P1 products also provide the lowest cost of entry for a double-wall, UL 103 listed product in the industry. P1 products are also UL 103HT, UL 1978 and UL 2561 listed.

All Schebler prefabricated chimney systems are known by the value they provide through unmatched dimensional accuracy and detailed draft calculations. These translate into fast project completion, lowered installation costs and satisfied customers.

With Schebler, we are certain you will find what thousands of our customers have found: we exceed expectations by providing high-quality products and services through a culture of empowerment, continuous improvement and innovation. Since our founding in 1895, we have fabricated high-quality, innovative products designed and built with expert craftsmanship and backed by impeccable support. Contact Schebler for more information about our chimney solutions, including help with custom engineering and design solutions.

Made in America by a Team of Dedicated Employee-Owners
FIND YOUR LOCAL SCHEBLER CHIMNEY SYSTEMS DISTRIBUTOR



5665 Fenno Rd.
Bettendorf, IA 52722

563.359.0110

scheblerchimney.com