



PRESENTING THE CERTAINTY OF SLIMVENT® GREASE DUCT PERFORMANCE

The Industry's Only Obround-Shaped Grease Duct

These prefabricated, double-wall, obround grease ducts are designed and built for specific project requirements, including horizontal runs. Their patented obround shape significantly reduces the necessary overhead space compared to a round duct and, with a two hour fire rating, eliminates the need for a fire-rated chase. Plus, it's backed by the certainty of Schebler, the leader in prefabricated grease duct systems.



FEATURING A FIRST-OF-ITS-KIND GASKET CONNECTION THAT DELIVERS:

GREATER SAFETY AND LOWER COSTS

We've nixed the traditional sealant and replaced it with a unique flange-to-flange, factory-applied gasket design with an inner collar that meets UL 1978 and UL 2221 listing requirements. This groundbreaking joint connection delivers better quality, enhanced safety and a lower cost.

FASTER INSTALLATION

By completely removing the lengthy and tiresome step of applying sealant, Schebler's exclusive gasket design greatly reduces installation time.

UL 1978 AND UL 2221 LISTED FIRE PROTECTION

When using sealant, a narrow bead can leave gaps, loose connections and unpredictable dangers. The Schebler gasket standardizes the joint connection, eliminating the possibility of improperly sealed joints.

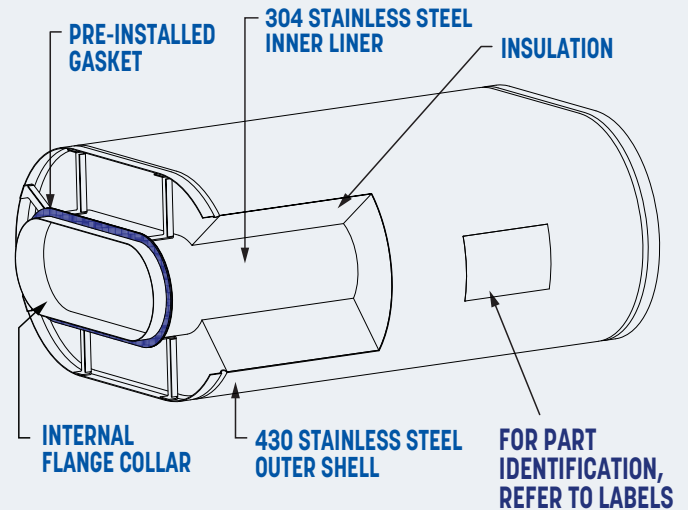

The Advantages of Prefabricated Manufacturing

By overseeing manufacturing in our U.S. factory, we produce more consistent, stronger, safer and more durable products. With Schebler, you get:

THE CERTAINTY OF CUSTOM ENGINEERING

Each of our product lines and their components is custom-made to match your specific requirements and measurements. By ensuring every detail is met, we provide smoother installation and more efficient products, every time.

THE CERTAINTY OF STEADFAST SUPPORT

Our products are backed by the industry's most elite engineering services and technical support. We check and re-check all required specifications and incorporate the resources necessary to meet and exceed your expectations.

THE CERTAINTY OF EXPERTISE

When we designed SlimVent, we tapped into our in-depth knowledge of grease duct systems, including their technical and regulatory requirements. Schebler is the expert in these applications and will help ensure your system meets all standards and codes, including NFPA, IMC and UMC.

5665 Fenno Rd.
Bettendorf, IA 52722

563.359.0110
scheblerchimney.com

From hospitals to restaurants, from school cafeterias to mixed-use buildings, SlimVent from Schebler make a world of difference in safety and affordability.

To bring certainty to your next project, find and contact your local Schebler Chimney Systems distributor.

